

# DS6500

## INSTALLATION QUICK REFERENCE



# CONTENTS

---

DS6500-100-010 MASTER/SLAVE MODEL .....1

DS6500-100-011 PROFIBUS MODEL .....8

DS6500-100-012 ETHERNET MODEL .....13

DS6500-100-015 DEVICENET MODEL .....18

DS6500-105-0XX OSCILLATING MIRROR MODEL .....23

COMMON FEATURES .....25

	<i>For further details on product installation, see the complete Reference Manual available on the configuration CD-ROM included with this product.</i>
<b>NOTE</b>	

## DS6500-100-010 MASTER/SLAVE MODEL

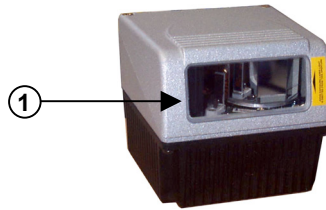

Figure A

① Laser Beam Output Window

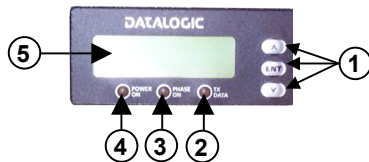

Figure B

- ① Programming Keypad
- ② TX Data LED (Green)
- ③ Phase On LED (Yellow)
- ④ Power On LED (Red)
- ⑤ LCD Display



Figure C

- ① Main/Aux. Interface 25-pin D-sub Male Connector
- ② Lonworks 9-pin Male Connector
- ③ Lonworks 9-pin Female Connector

### Available Models:

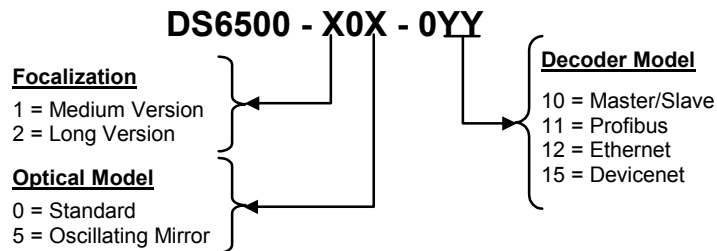

### Technical Features:

ELECTRICAL FEATURES		OPTICAL FEATURES		
Supply Voltage	15 - 30 Vdc		Light Receiver	Avalanche photodiode
Power Consumption	15 W typical 20 W Max. (including startup current)		Wavelength	630 to 680 nm
Communication Interfaces	<b>Main (isolated)</b>	Baud Rate 1200 to 115200	Safety Class	Class 2-EN 60825-1; Class II-CDRH
	RS232		Laser Control	Security system to turn laser off in case of motor slow down
	RS485 full-duplex			
	RS485 half-duplex	Auxiliary	<b>READING FEATURES</b>	
	20 mA C.L. (INT-30 with C-BOX 100 only)		19200	Scan Rate
Inputs Ext. Trigger 1, 3 aux. digital inputs	RS232	1200 to 115200	Max. Resolution Max. Read. Distance Max. Read. Width Max. Depth of Field	(see reading diagram)
	<b>Other</b>			
	Lonworks	1,25 Mb/s		
Outputs 3 software programmable digital outputs	(opt coupled NPN or PNP)		<b>USER INTERFACE</b>	
	(optocoupled)		LCD Display	2 lines by 16 characters LCD
			Keypad	3 keys
		LED Indicators	Power ON (red color) Phase ON (yellow color) TX Data (green color)	

SOFTWARE FEATURES		ENVIRONMENTAL FEATURES	
<b>Readable Codes</b>	Interleaved 2/5 Code 39 standard Codabar Code 128 EAN 128 Code 93 (Standard & Full ASCII) EAN/UPC (including Add-on 2 And Add-on 5)	<b>Operating Temperature</b>	0° to +40 °C (+32 to +104 °F)
		<b>Storage Temperature</b>	-20° to +70 °C (-4° to +158 °F)
		<b>Humidity</b>	90% non condensing
		<b>Ambient Light Immunity</b>	3500 lux
<b>Code Selection</b>	Up to 10 codes during one reading phase	<b>Vibration Resistance</b>	14 mm @ 2 to 10 Hz IEC 68-2-6 test FC 2 hours on each axis
<b>Headers and Terminators</b>	Up to 128-byte headers and 128-byte terminators	<b>Shock Resistance</b>	1.5 mm @ 13 to 55 Hz 2 g @ 70 to 200 Hz
<b>Operating Modes</b>	On Line, Automatic, Test, PackTrack™	IEC 68-2-27 test EA	30 g; 11 ms
<b>Config. Mode</b>	Genius™ utility program	<b>Protection Class</b>	IP64
<b>Parameter Storage</b>	Non-volatile internal FLASH	PHYSICAL FEATURES	
		<b>Std Models</b>	<b>Oscill. Mirror</b>
		<b>Dimensions mm (inch)</b>	110x113x99 (4.33x4.45x3.9) 113x180x104.5 (4.45x7.08x4.11)
		<b>Weight</b>	1.5 kg (3.3 lb) 2.0 kg (4.4 lb)

### Accessories:

Name	Description	Part Number
CAB-6001	Cable to C-BOX100 1 m	93A051190
CAB-6002	Cable to C-BOX100 2 m	93A051200
CAB-6005	Cable to C-BOX100 5 m	93A051210
CAB-6010	Cable to C-BOX100 10 m	93A051271
CAB-6101	Cable master/slave 1 m	93A051220
CAB-6102	Cable master/slave 2 m	93A051230
CAB-6105	Cable master/slave 5 m	93A051240
CAB-6112	Cable master/slave no power 2 m	93A051224
CAB-6115	Cable master/slave no power 5 m	93A051225
CAB-6305	Power cable Fam 6k 5 m	93ACC1768
CAB-6310	Power cable Fam 6k 10 m	93ACC1752
C-BOX 100	Passive connection box	93ACC1510
INT-30	20 mA C.L. interface board for C-BOX 100	93A151022
GFC-60	90° mirror	93A201100
GFC-600	90° mirror close distance	93A201102
PWR-120	Power unit 110/230 V AC - 24 V DC	93ACC1530
BTK-6000	Terminator kit (5 pcs)	93ACC1710
PG6002	Single unit power supply – US	93ACC1718
PG6001	Single unit power supply – UK	93ACC1719
PG6000	Single unit power supply – EU	93ACC1720
FBK-6000	Fast bracket kit (2 pcs)	93ACC1721
US-60	Mounting bracket kit (5 pcs) for multisided stations	890001020
MEP-542	Photocell kit – PNP	93ACC1727
MEP-543	Photocell kit – NPN	93ACC1728
OEK-2	Optical encoder (10 m cable + spring)	93ACC1770
OEK-1	Optical encoder kit + 10 m cable	93ACC1600

### Electrical Connections:

The DS6500 reader provides a 25-pin male D-sub connector for connection to power supply, Host interface (Main and Aux), and input/output signals.

Two 9-pin connectors provide access to the scanner's local Lonworks network used for both input and output connections to build a multi-sided or omni-station system.

The details of the connector pins are indicated in the following table:

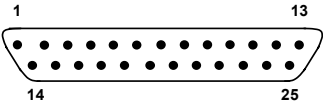
25-pin D-Sub Connector Pinout						
Pin	Name	Function				
1	CHASSIS	Chassis - internally connected to GND Cable shield connected to chassis	 <p>25-pin male D-sub Connector</p>			
20	RXAUX	Receive data of auxiliary RS232 (referred to GND)				
21	TXAUX	Transmit data of auxiliary RS232 (referred to GND)				
8	OUT 1+	Configurable digital output 1 – positive pin				
22	OUT 1-	Configurable digital output 1 – negative pin				
11	OUT 2+	Configurable digital output 2 – positive pin				
12	OUT 2-	Configurable digital output 2 – negative pin				
16	OUT 3A	Configurable digital output 3 – polarity insensitive				
17	OUT 3B	Configurable digital output 3 – polarity insensitive				
18	EXT_TRIG/PS A	External trigger (polarity insensitive) for PS				
19	EXT_TRIG/PS B	External trigger (polarity insensitive) for PS				
6	IN2/ENC A	Input signal 2 (polarity insensitive) for Encoder				
10	IN2/ENC B	Input signal 2 (polarity insensitive) for Encoder				
14	IN3A	Input signal 3 (polarity insensitive)				
15	IN4A	Input signal 4 (polarity insensitive)				
24	IN_REF	Common reference of IN3 and IN4 (polarity insensitive)				
9, 13	VS	Supply voltage – positive pin				
23, 25	GND	Supply voltage – negative pin				
Pin	RS232	RS485 Full-Duplex			RS485 Half-Duplex	20 mA C.L. (INT-30 with C-BOX 100 only)
2	TX	TX485+			RTX485+	see INT-30 instructions
3	RX	RX485+			RTX485+	
4	RTS	TX485-			RTX485-	
5	CTS	RX485-			RTX485-	
7	GND_ISO	GND_ISO			GND_ISO	

\* For 20 mA C.L. connections, GND is the same of the scanner power supply.

9-pin Lonworks Connector Pinout		
Pin	Name	Function
1	CHASSIS	Cable shield internally connected by capacitor to chassis
9	VS	Supply voltage – positive pin
2	GND	Supply voltage – negative pin
6	VS_I/O	Supply voltage of I/O circuit
3	Ref_I/O	Reference voltage of I/O circuit
4	SYS_ENC_I/O	System signal
5	SYS_I/O	System signal
7	LON A	Lonworks line (polarity insensitive)
8	LON B	Lonworks line (polarity insensitive)

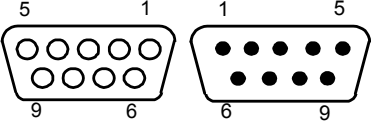

Female Male

**9-pin Local Lonworks Connectors**

## Network Termination:

When building a local Lonworks system the network must be properly terminated by positioning a BTK-6000 terminator on the DS6500 master reader (BTK-6000 female side) and on the last slave reader (BTK-6000 male side).

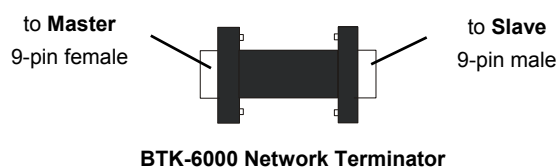

## Connectivity:

### Point-to-Point Layout

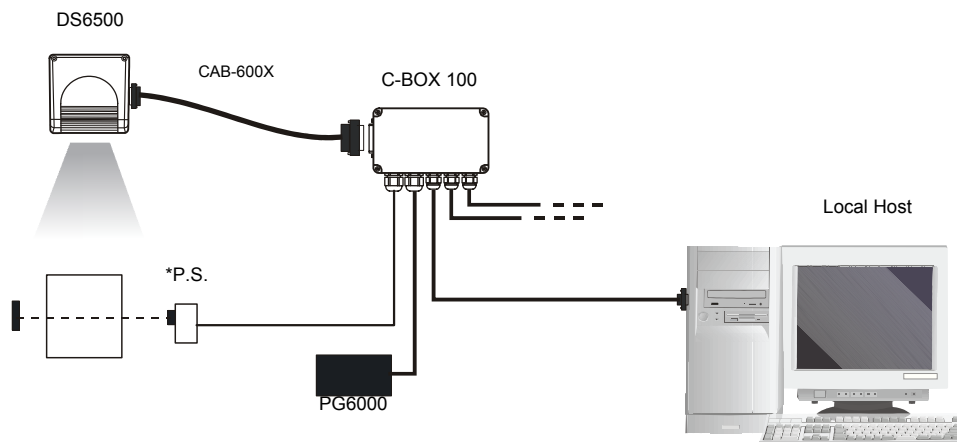

\* P.S. (Presence Sensor) connected to External Trigger/PS input.

### Pass Through Layout

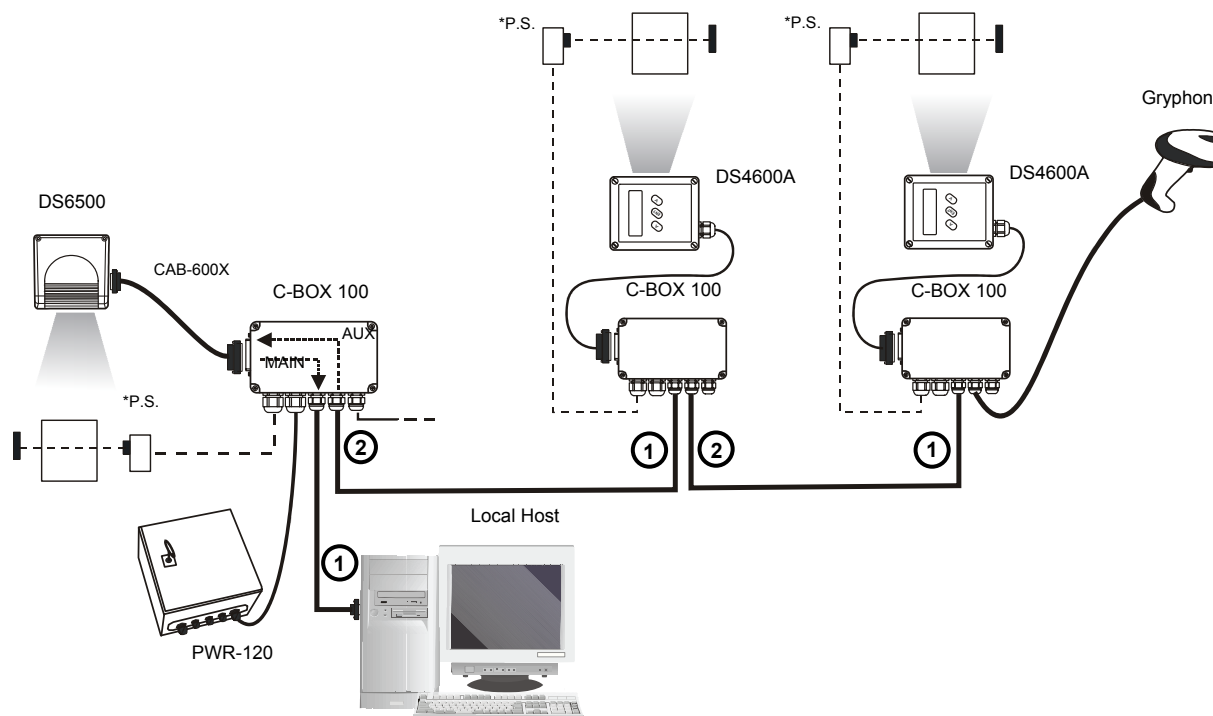

- ① Main Serial Interface
- ② Auxiliary Serial Interface

\* P.S. (Presence Sensor) connected to External Trigger/PS input.

### Multiplexer Layout

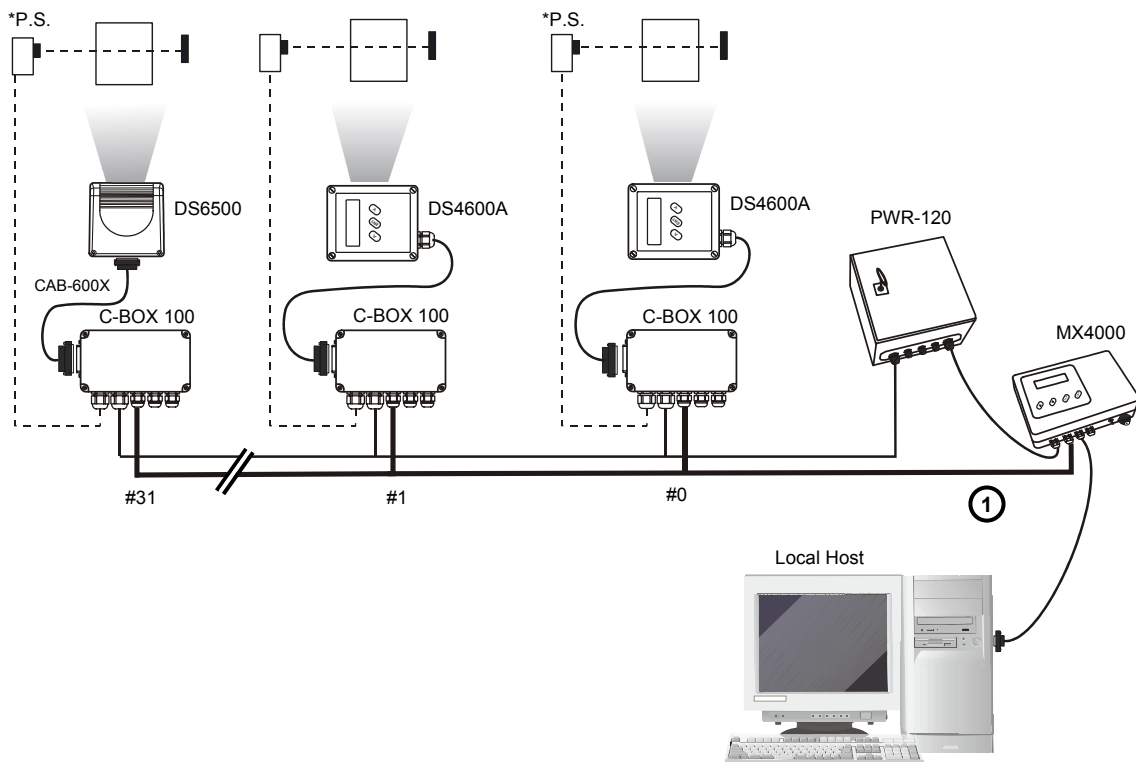

① RS485 HD Main Interface

\* P.S. (Presence Sensor) connected to External Trigger/PS input.

### RS232 Master/Slave Layout

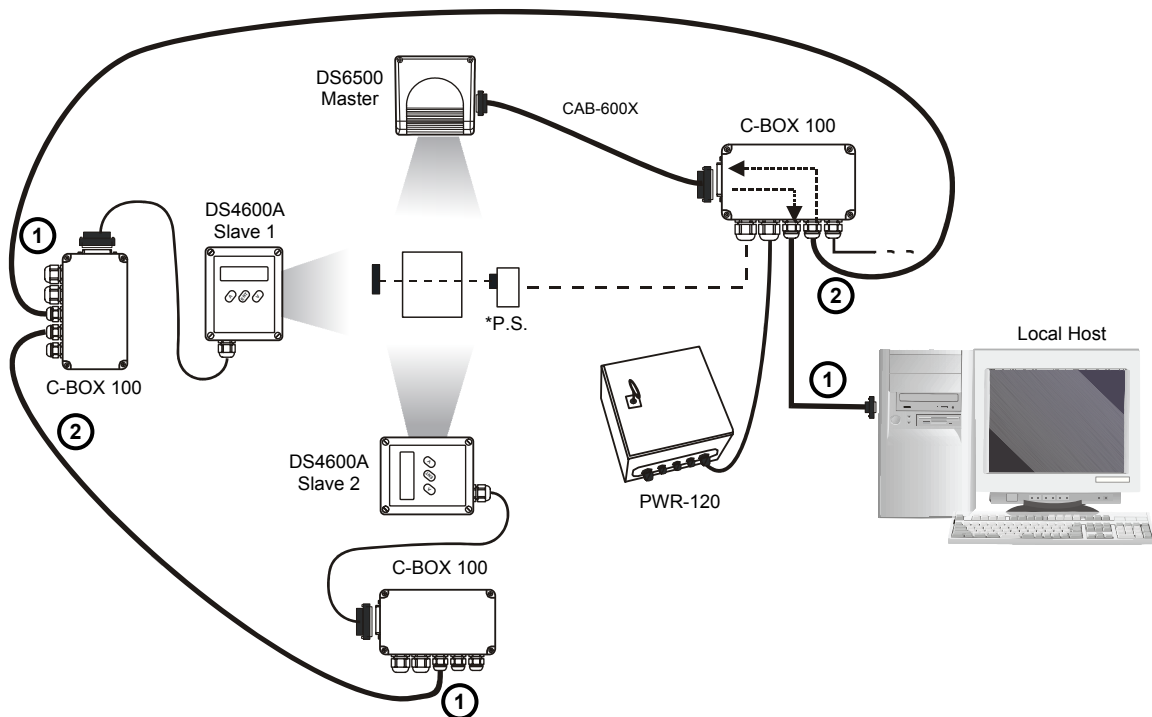

① Main Serial Interface

② Auxiliary Serial Interface

\* P.S. (Presence Sensor) connected to External Trigger/PS input.

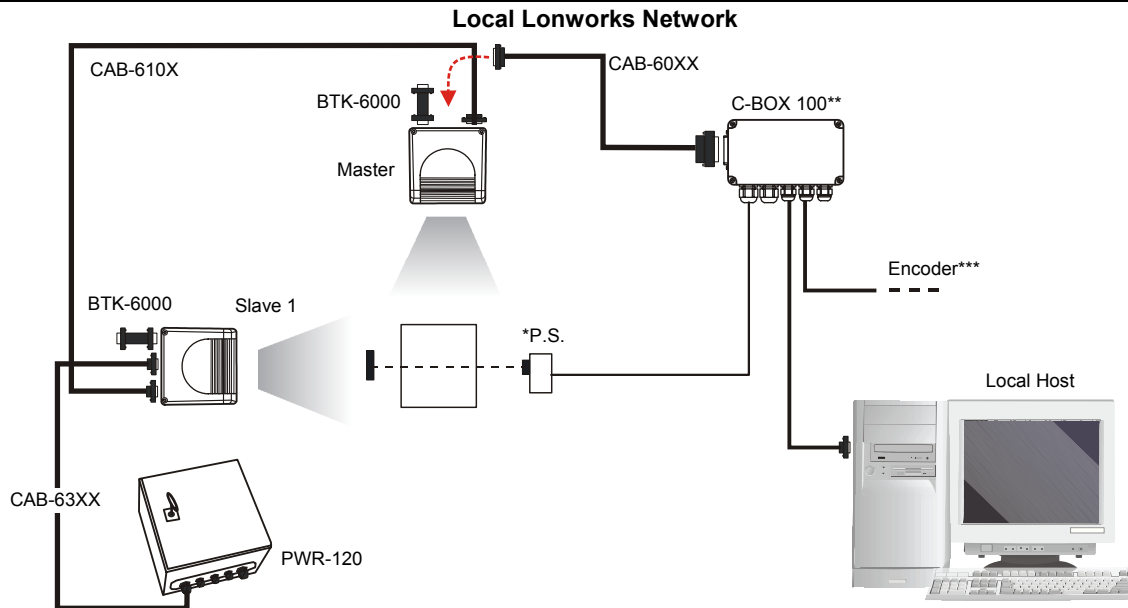

**Small Synchronized Network with 2 Readers**

- \* P.S. (Presence Sensor) connected to External Trigger/PS input.
- \*\* C-BOX 100 modified to accept scanner power.
- \*\*\* Encoder connected to IN2/ENC input.

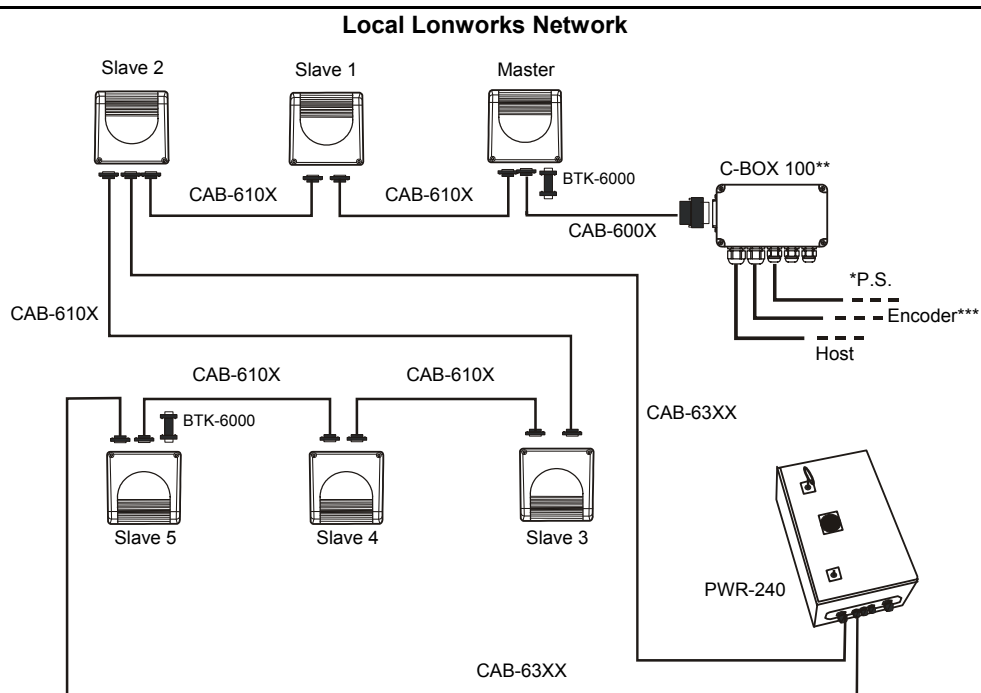

**Small Synchronized Network with more than 2 Readers and Single Power Unit**

- \* P.S. (Presence Sensor) connected to External Trigger/PS input.
- \*\* C-BOX 100 modified to accept scanner power.
- \*\*\* Encoder connected to IN2/ENC input.



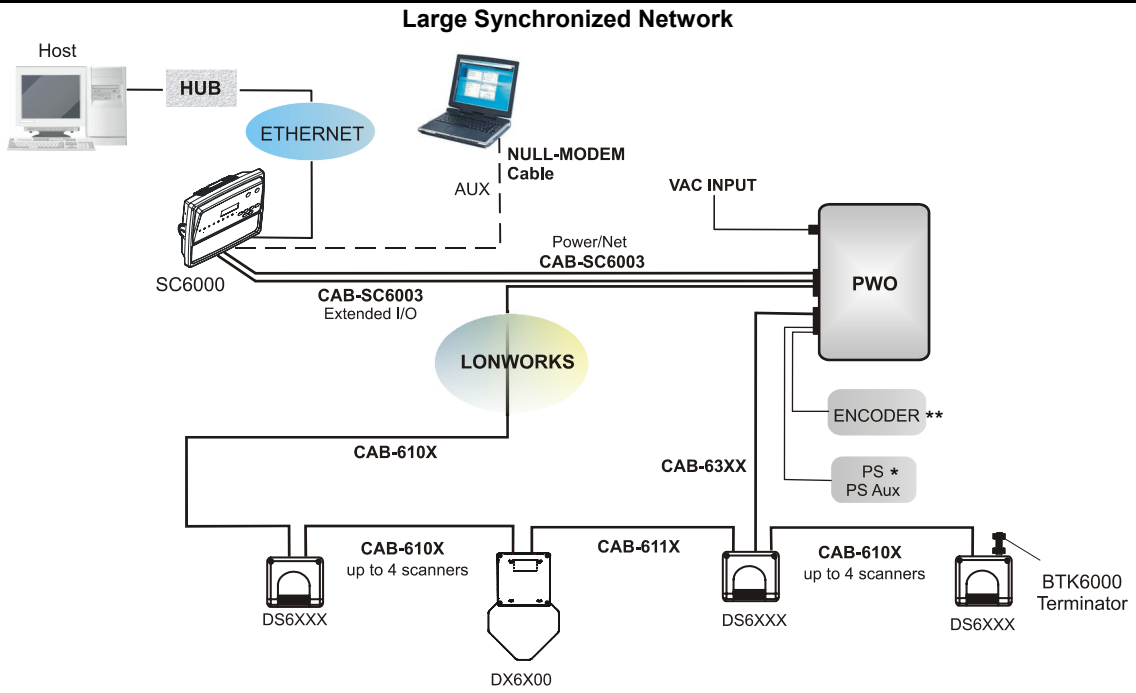

\* P.S. (Presence Sensor) connected to External Trigger/PS input.

\*\* Encoder connected to IN2/ENC input.

**Large Synchronized Network with DX6X00 and DS6XXX Scanners**

## DS6500-100-011 PROFIBUS MODEL

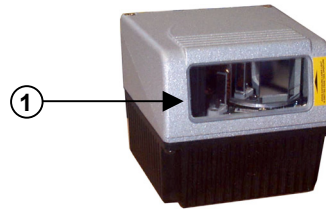

Figure A

① Laser Beam Output Window

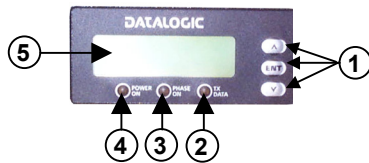

Figure B

- ① Programming Keypad
- ② TX Data LED (Green)
- ③ Phase On LED (Yellow)
- ④ Power On LED (Red)
- ⑤ LCD Display

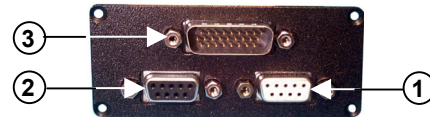
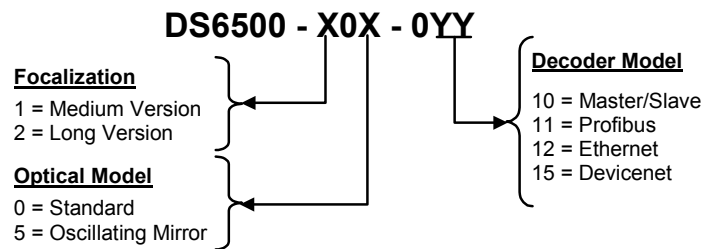

Figure C

- ① Profibus 9-pin Female Connector (white)
- ② Lonworks 9-pin Female Connector
- ③ Main/Aux. Interface 26-pin D-Sub Male Connector

### Available Models:



### Technical Features:

ELECTRICAL FEATURES		OPTICAL FEATURES			
<b>Supply Voltage</b>	15 - 30 Vdc	<b>Light Receiver</b>	Avalanche photodiode		
<b>Power Consumption</b>	15 W typical 20 W Max. (including startup current)	<b>Wavelength</b>	630 to 680 nm		
<b>Communication Interfaces</b>	<b>Main (isolated)</b>	<b>Safety Class</b>	Class 2-EN 60825-1; Class II-CDRH		
	RS232	<b>Baud Rate</b>	<b>Laser Control</b>		
	RS485 full-duplex			1200 to 115200	Security system to turn laser off in case of motor slow down
	RS485 half-duplex				
	20 mA C.L. (INT-30 with C-BOX 100 only)	19200	<b>READING FEATURES</b>		
	<b>Auxiliary</b>		<b>Scan Rate</b>	600-1200 scans/s	
	RS232	1200 to 115200	<b>Max. Resolution</b> <b>Max. Read. Distance</b> <b>Max. Read. Width</b> <b>Max. Depth of Field</b>	(see reading diagram)	
<b>Other</b>					
Lonworks	1,25 Mb/s				
Profibus	12 Mb/s				
<b>Inputs</b>		<b>USER INTERFACE</b>			
<b>Ext. Trigger 1, 3 aux. digital inputs</b>	(optocoupled NPN or PNP)	<b>LCD Display</b>	2 lines by 16 characters LCD		
<b>Outputs</b>		<b>Keypad</b>	3 keys		
<b>3 software programmable digital outputs</b>	(optocoupled)	<b>LED Indicators</b>	Power ON (red color) Phase ON (yellow color) TX Data (green color)		

SOFTWARE FEATURES		ENVIRONMENTAL FEATURES	
<b>Readable Codes</b>	Interleaved 2/5 Code 39 standard Codabar Code 128 EAN 128 Code 93 (Standard & Full ASCII) EAN/UPC (including Add-on 2 And Add-on 5)	<b>Operating Temperature</b>	0° to +40 °C (+32 to +104 °F)
		<b>Storage Temperature</b>	-20° to +70 °C (-4° to +158 °F)
		<b>Humidity</b>	90% non condensing
		<b>Ambient Light Immunity</b>	3500 lux
<b>Code Selection</b>	Up to 10 codes during one reading phase	<b>Vibration Resistance</b>	14 mm @ 2 to 10 Hz IEC 68-2-6 test FC 2 hours on each axis
<b>Headers and Terminators</b>	Up to 128-byte headers and 128-byte terminators	<b>Shock Resistance</b>	1.5 mm @ 13 to 55 Hz 2 g @ 70 to 200 Hz
<b>Operating Modes</b>	On Line, Automatic, Test, PackTrack™	IEC 68-2-27 test EA	30 g; 11 ms
<b>Config. Mode</b>	Genius™ utility program	<b>Protection Class</b>	IP64
<b>Parameter Storage</b>	Non-volatile internal FLASH	PHYSICAL FEATURES	
		<b>Std Models</b>	<b>Oscill. Mirror</b>
		<b>Dimensions mm (inch)</b>	110x113x99 (4.33x4.45x3.9) 113x180x104.5 (4.45x7.08x4.11)
		<b>Weight</b>	1.5 kg (3.3 lb) 2.0 kg (4.4 lb)

## Accessories:

Name	Description	Part Number
CAB-6011	Cable to C-BOX100 1 m	93A051221
CAB-6012	Cable to C-BOX100 2 m	93A051222
CAB-6015	Cable to C-BOX100 5 m	93A051223
C-BOX 100	Passive connection box	93ACC1510
INT-30	20 mA C.L. interface board for C-BOX 100	93A151022
GFC-60	90° mirror	93A201100
GFC-600	90° mirror close distance	93A201102
PWR-120	Power unit 110/230 V AC - 24 V DC	93ACC1530
BTK-6000	Terminator kit (5 pcs)	93ACC1710
PG6002	Single unit power supply – US	93ACC1718
PG6001	Single unit power supply – UK	93ACC1719
PG6000	Single unit power supply – EU	93ACC1720
FBK-6000	Fast bracket kit (2 pcs)	93ACC1721
US-60	Mounting bracket kit (5 pcs) for multisided stations	890001020
MEP-542	Photocell kit – PNP	93ACC1727
MEP-543	Photocell kit – NPN	93ACC1728
OEK-2	Optical encoder (10 m cable + spring)	93ACC1770
OEK-1	Optical encoder kit + 10 m cable	93ACC1600

## Electrical Connections:

The DS6500 Ethernet reader provides a 26-pin male D-sub connector for connection to power supply and input/output signals.

An Ethernet connector is used for connection to the remote Host (for ex. Remote PC connected via Internet), while a local Lonworks 9-pin female connector connects the Ethernet master to the first slave reader of the system.

The details of the connector pins are indicated in the following table:

26-pin D-Sub Connector Pinout				
Pin	Name	Function		
1	CHASSIS	Chassis - internally connected to GND		
20	RXAUX	Cable shield connected to chassis		
21	TXAUX	Receive data of auxiliary RS232 (referred to GND)		
8	OUT 1+	Transmit data of auxiliary RS232 (referred to GND)		
22	OUT 1-	Configurable digital output 1 – positive pin		
11	OUT 2+	Configurable digital output 1 – negative pin		
12	OUT 2-	Configurable digital output 2 – positive pin		
16	OUT 3A	Configurable digital output 2 – negative pin		
17	OUT 3B	Configurable digital output 3 – polarity insensitive		
18	EXT_TRIG/PS A	Configurable digital output 3 – polarity insensitive		
19	EXT_TRIG/PS B	External trigger (polarity insensitive) for PS		
6	IN2/ENC A	External trigger (polarity insensitive) for PS		
10	IN2/ENC B	Input signal 2 (polarity insensitive) for Encoder		
14	IN3A	Input signal 2 (polarity insensitive) for Encoder		
15	IN4A	Input signal 3 (polarity insensitive)		
24	IN_REF	Input signal 4 (polarity insensitive)		
9, 13	VS	Common reference of IN3 and IN4 (polarity insensitive)		
23, 25, 26	GND	Supply voltage – positive pin		
		Supply voltage – negative pin		

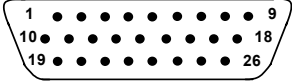

**26-pin male D-sub Connector**

Pin	RS232	RS485 Full-Duplex	RS485 Half-Duplex	20 mA C.L. (INT-30 with C-BOX 100 only)
2	TX	TX485+	RTX485+	see INT-30 instructions
3	RX	RX485+		
4	RTS	TX485-	RTX485-	
5	CTS	RX485-		
7	GND_ISO	GND_ISO	GND_ISO	

\* For 20 mA C.L. connections, GND is the same of the scanner power supply.

9-pin Lonworks Connector Pinout		
Pin	Name	Function
1	CHASSIS	Cable shield internally connected by capacitor to chassis
9	VS	Supply voltage – positive pin
2	GND	Supply voltage – negative pin
6	VS_I/O	Supply voltage of I/O circuit
3	Ref_I/O	Reference voltage of I/O circuit
4	SYS_ENC_I/O	System signal
5	SYS_I/O	System signal
7	LON A	Lonworks line (polarity insensitive)
8	LON B	Lonworks line (polarity insensitive)

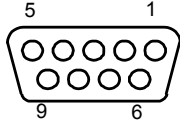

**9-pin female Local Lonworks Connector**

9-pin Profibus Connector		
Pin	Name	Function
1	Shield	Shield, Protective Ground resp. (optional)
2	Free	
3	B-LINE (Rx/D/TxD-P)	Received/Transmitted Data-P
4	CNTR-P	Repeater Control Signal (optional, RS485 level)
5	DGND	Data Ground (M5V)
6	+5 V	Voltage Plus (P5V)
7	Free	
8	A-LINE (Rx/D/TxD-N)	Received/Transmitted Data
9	CNTR-N	Repeater Control Signal

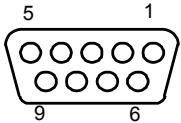

**9-pin female Profibus Connector (white)**

## Connectivity:

### Point-to-Point Layout

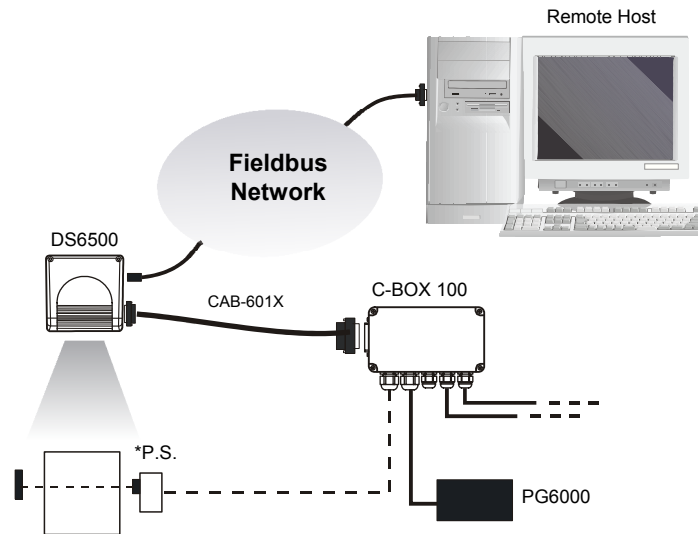

\* P.S. (Presence Sensor) connected to External Trigger/PS input.

### Pass Through Layout

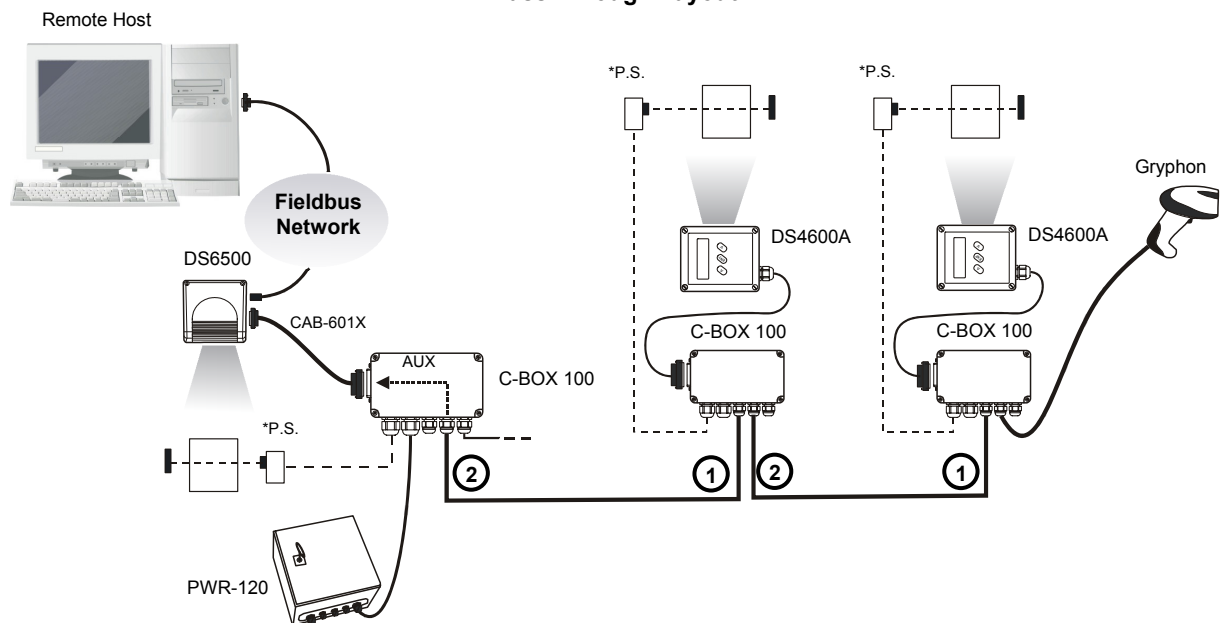

① Main Serial Interface      ② Auxiliary Serial Interface

\* P.S. (Presence Sensor) connected to External Trigger/PS input.

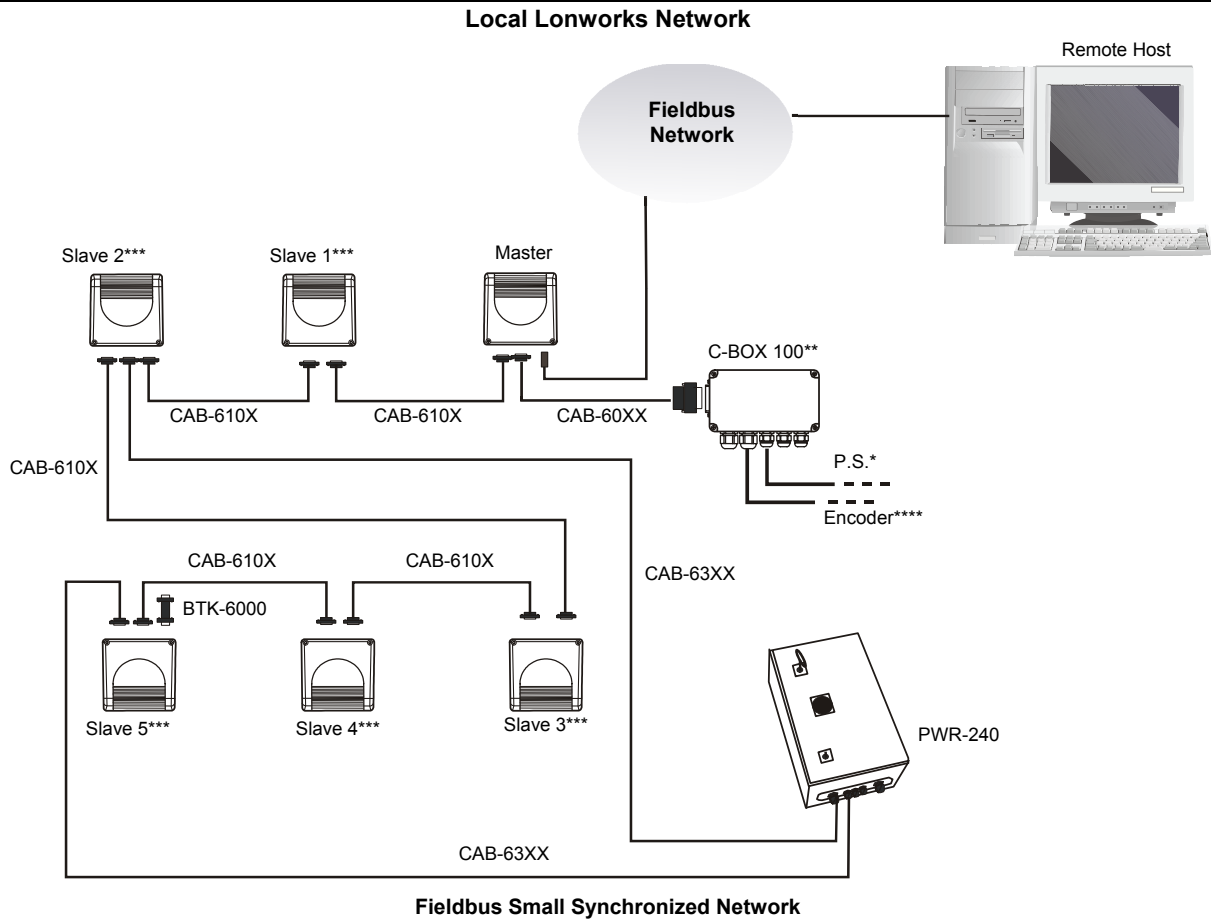

- \* P.S. (Presence Sensor) connected to External Trigger/PS input.
- \*\* C-BOX 100 modified to accept scanner power.
- \*\*\* The Slave scanners are Master/Slave models, which allow Lonworks network propagation.
- \*\*\*\* Encoder connected to IN2/ENC input.

## DS6500-100-012 ETHERNET MODEL

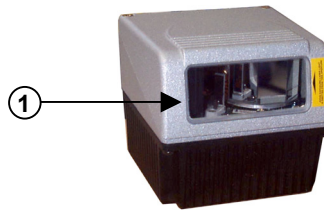

**Figure A**

① Laser Beam Output Window

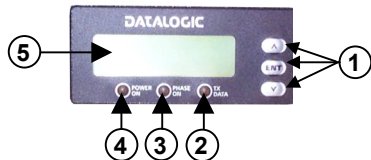

**Figure B**

- ① Programming Keypad
- ② TX Data LED (Green)
- ③ Phase On LED (Yellow)
- ④ Power On LED (Red)
- ⑤ LCD Display

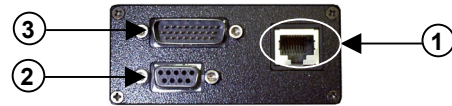

**Figure C**

- ① RJ45 Modular Connector for Ethernet Interface
- ② Lonworks 9-pin Female Connector
- ③ Main/Aux. Interface 26-pin D-Sub Male Connector

### Available Models:

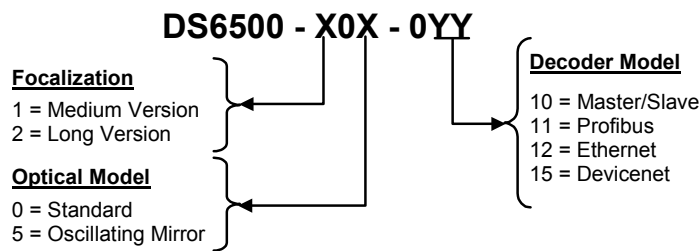

### Technical Features:

ELECTRICAL FEATURES		OPTICAL FEATURES			
<b>Supply Voltage</b>	15 - 30 Vdc	<b>Light Receiver</b>	Avalanche photodiode		
<b>Power Consumption</b>	15 W typical 20 W Max. (including startup current)	<b>Wavelength</b>	630 to 680 nm		
<b>Communication Interfaces</b>	<b>Main (isolated)</b>	<b>Baud Rate</b>	<b>Safety Class</b>		
	RS232			1200 to 115200	Class 2-EN 60825-1; Class II-CDRH
	RS485 full-duplex				
	RS485 half-duplex	19200	<b>Laser Control</b>	Security system to turn laser off in case of motor slow down	
	20 mA C.L. (INT-30 with C-BOX 100 only)		<b>READING FEATURES</b>		
	<b>Auxiliary</b>		<b>Scan Rate</b>	600-1200 scans/s	
RS232	1200 to 115200	<b>Max. Resolution</b> <b>Max. Read. Distance</b> <b>Max. Read. Width</b> <b>Max. Depth of Field</b>	(see reading diagram)		
<b>Other</b>					
Lonworks	1,25 Mb/s				
Ethernet	10 or 100 Mb/s				
<b>Inputs</b>		<b>USER INTERFACE</b>			
<b>Ext. Trigger 1, 3 aux. digital inputs</b>	(optocoupled NPN or PNP)	<b>LCD Display</b>	2 lines by 16 characters LCD		
<b>Outputs</b>		<b>Keypad</b>	3 keys		
<b>3 software programmable digital outputs</b>	(optocoupled)	<b>LED Indicators</b>	Power ON (red color) Phase ON (yellow color) TX Data (green color)		

SOFTWARE FEATURES		ENVIRONMENTAL FEATURES		
<b>Readable Codes</b>	Interleaved 2/5 Code 39 standard Codabar Code 128 EAN 128 Code 93 (Standard & Full ASCII) EAN/UPC (including Add-on 2 And Add-on 5)	<b>Operating Temperature</b>	0° to +40 °C (+32 to +104 °F)	
		<b>Storage Temperature</b>	-20° to +70 °C (-4° to +158 °F)	
<b>Code Selection</b>	Up to 10 codes during one reading phase	<b>Humidity</b>	90% non condensing	
		<b>Ambient Light Immunity</b>	3500 lux	
<b>Headers and Terminators</b>	Up to 128-byte headers and 128-byte terminators	<b>Vibration Resistance</b>	14 mm @ 2 to 10 Hz 1.5 mm @ 13 to 55 Hz 2 g @ 70 to 200 Hz	
		<b>Shock Resistance</b>	30 g; 11 ms	
<b>Operating Modes</b>	On Line, Automatic, Test, PackTrack™	<b>Protection Class</b>	IP50	
<b>Config. Mode</b>	Genius™ utility program	PHYSICAL FEATURES		
<b>Parameter Storage</b>	Non-volatile internal FLASH		<b>Std Models</b>	<b>Oscill. Mirror</b>
		<b>Dimensions mm (inch)</b>	110x113x99 (4.33x4.45x3.9)	113x180x104.5 (4.45x7.08x4.11)
		<b>Weight</b>	1.5 kg (3.3 lb)	2.0 kg (4.4 lb)

## Accessories:

Name	Description	Part Number
CAB-6011	Cable to C-BOX100 1 m	93A051221
CAB-6012	Cable to C-BOX100 2 m	93A051222
CAB-6015	Cable to C-BOX100 5 m	93A051223
C-BOX 100	Passive connection box	93ACC1510
INT-30	20 mA C.L. interface board for C-BOX 100	93A151022
GFC-60	90° mirror	93A201100
GFC-600	90° mirror close distance	93A201102
PWR-120	Power unit 110/230 V AC - 24 V DC	93ACC1530
BTK-6000	Terminator kit (5 pcs)	93ACC1710
PG6002	Single unit power supply – US	93ACC1718
PG6001	Single unit power supply – UK	93ACC1719
PG6000	Single unit power supply – EU	93ACC1720
FBK-6000	Fast bracket kit (2 pcs)	93ACC1721
US-60	Mounting bracket kit (5 pcs) for multisided stations	890001020
MEP-542	Photocell kit – PNP	93ACC1727
MEP-543	Photocell kit – NPN	93ACC1728
OEK-2	Optical encoder (10 m cable + spring)	93ACC1770
OEK-1	Optical encoder kit + 10 m cable	93ACC1600

## Electrical Connections:

The DS6500 Ethernet reader provides a 26-pin male D-sub connector for connection to power supply and input/output signals.

An Ethernet connector is used for connection to the remote Host (for ex. Remote PC connected via Internet), while a local Lonworks 9-pin female connector connects the Ethernet master to the first slave reader of the system.

The details of the connector pins are indicated in the following table:



26-pin D-Sub Connector Pinout				
Pin	Name	Function		
1	CHASSIS	Chassis - internally connected to GND		
20	RXAUX	Cable shield connected to chassis		
21	TXAUX	Receive data of auxiliary RS232 (referred to GND)		
8	OUT 1+	Transmit data of auxiliary RS232 (referred to GND)		
22	OUT 1-	Configurable digital output 1 – positive pin		
11	OUT 2+	Configurable digital output 1 – negative pin		
12	OUT 2-	Configurable digital output 2 – positive pin		
16	OUT 3A	Configurable digital output 2 – negative pin		
17	OUT 3B	Configurable digital output 3 – polarity insensitive		
18	EXT_TRIG/PS A	Configurable digital output 3 – polarity insensitive		
19	EXT_TRIG/PS B	External trigger (polarity insensitive) for PS		
6	IN2/ENC A	External trigger (polarity insensitive) for PS		
10	IN2/ENC B	Input signal 2 (polarity insensitive) for Encoder		
14	IN3A	Input signal 2 (polarity insensitive) for Encoder		
15	IN4A	Input signal 3 (polarity insensitive)		
24	IN_REF	Input signal 4 (polarity insensitive)		
9, 13	VS	Common reference of IN3 and IN4 (polarity insensitive)		
23, 25, 26	GND	Supply voltage – positive pin		
		Supply voltage – negative pin		

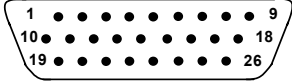

**26-pin male D-sub Connector**

Pin	RS232	RS485 Full-Duplex	RS485 Half-Duplex	20 mA C.L. (INT-30 with C-BOX 100 only)
2	TX	TX485+	RTX485+	see INT-30 instructions
3	RX	RX485+	RTX485+	
4	RTS	TX485-	RTX485-	
5	CTS	RX485-	GND_ISO	
7	GND_ISO	GND_ISO	GND_ISO	

\* For 20 mA C.L. connections, GND is the same of the scanner power supply.

9-pin Lonworks Connector Pinout		
Pin	Name	Function
1	CHASSIS	Cable shield internally connected by capacitor to chassis
9	VS	Supply voltage – positive pin
2	GND	Supply voltage – negative pin
6	VS_I/O	Supply voltage of I/O circuit
3	Ref_I/O	Reference voltage of I/O circuit
4	SYS_ENC_I/O	System signal
5	SYS_I/O	System signal
7	LON A	Lonworks line (polarity insensitive)
8	LON B	Lonworks line (polarity insensitive)

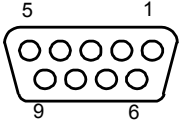

**9-pin female Local Lonworks Connector**

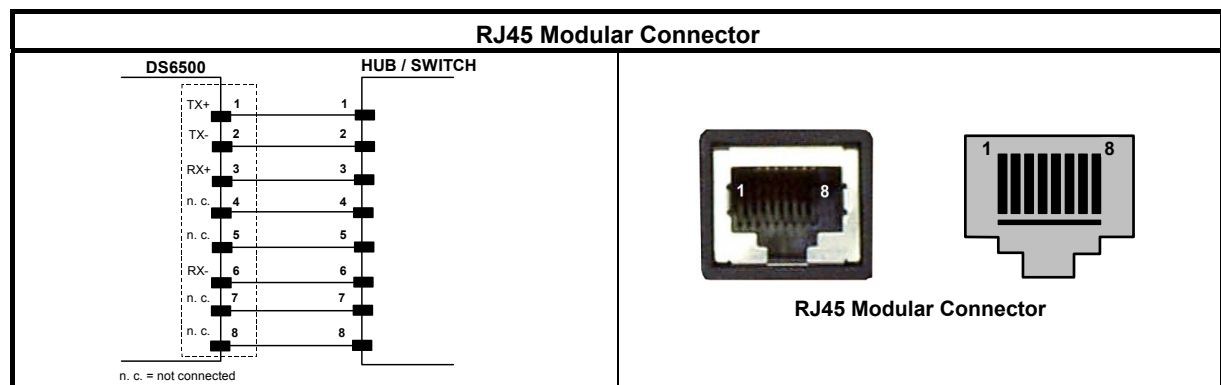

## Connectivity:

### Point-to-Point Layout

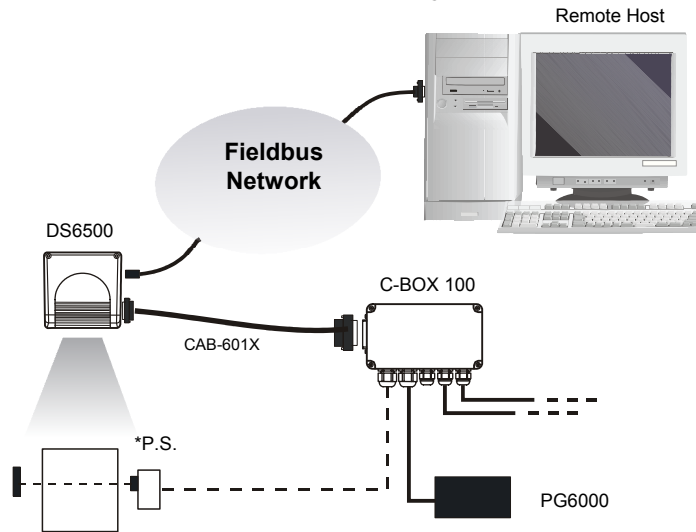

\* P.S. (Presence Sensor) connected to External Trigger/PS input.

### Pass Through Layout

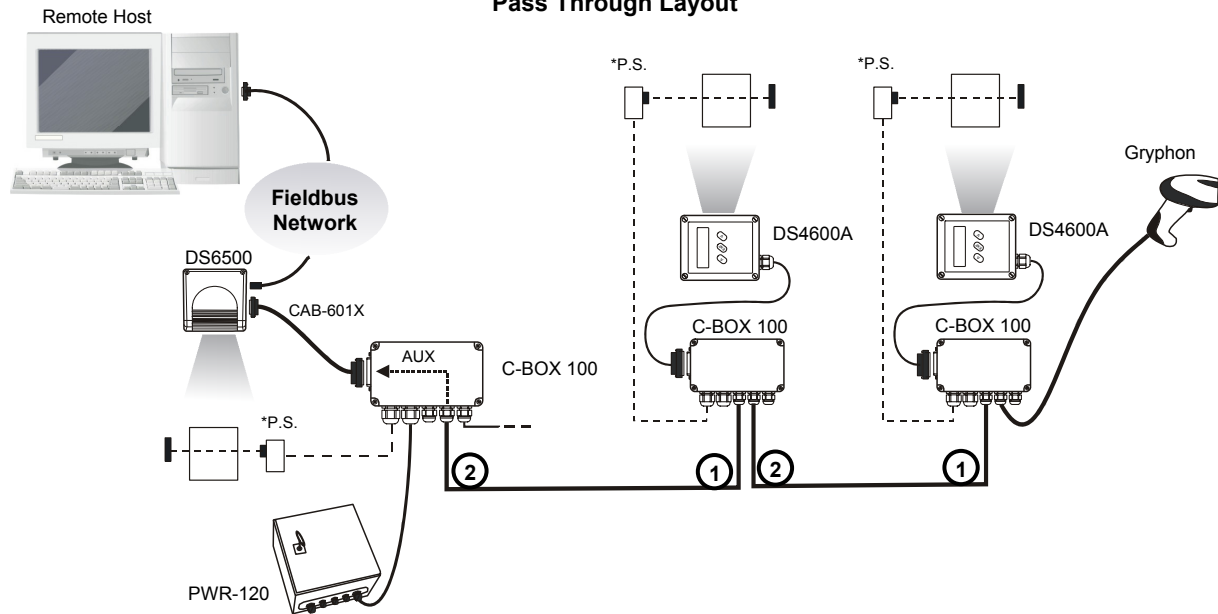

① Main Serial Interface      ② Auxiliary Serial Interface

\* P.S. (Presence Sensor) connected to External Trigger/PS input.

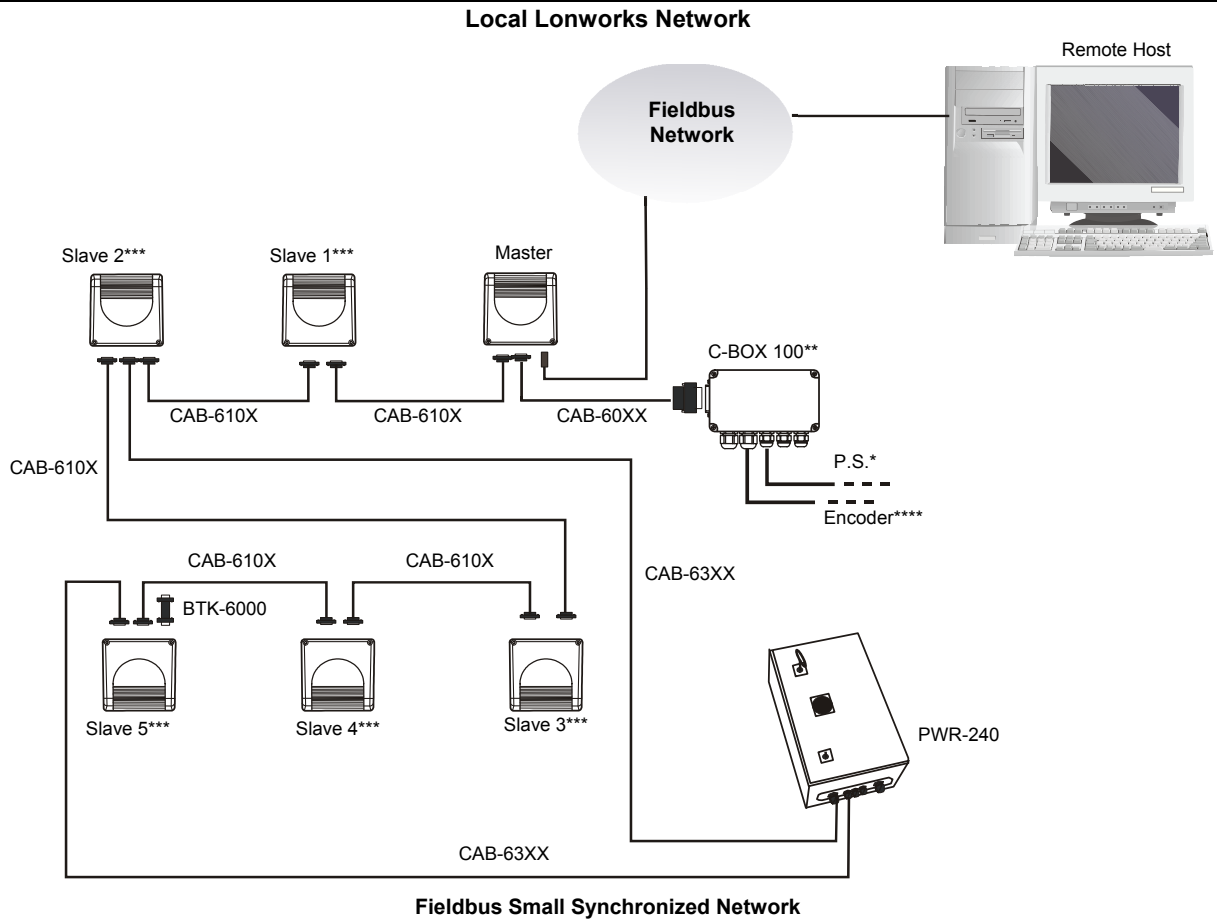

- \* P.S. (Presence Sensor) connected to External Trigger/PS input.
- \*\* C-BOX 100 modified to accept scanner power.
- \*\*\* The Slave scanners are Master/Slave models, which allow Lonworks network propagation.
- \*\*\*\* Encoder connected to IN2/ENC input.

## DS6500-100-015 DEVICENET MODEL

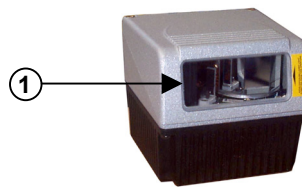

Figure A

① Laser Beam Output Window

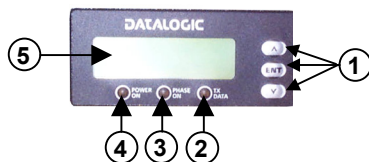

Figure B

① Programming Keypad

④ Power On LED (Red)

② TX Data LED (Green)

⑤ LCD Display

③ Phase On LED (Yellow)

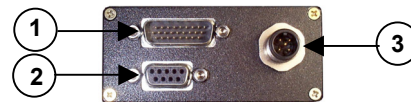

Figure C

① Main/Aux. Interface 26-pin D-sub Male Connector

② Lonworks 9-pin Female Connector

③ DeviceNet 5-pin Male Connector

### Available Models:

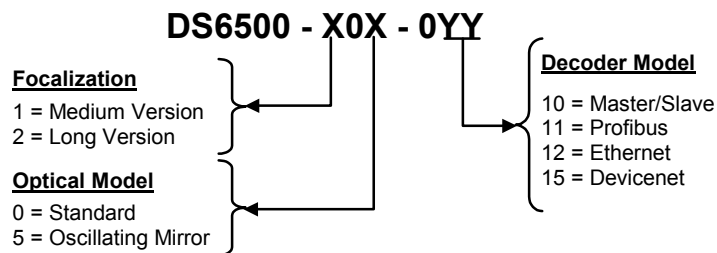

### Technical Features:

ELECTRICAL FEATURES		OPTICAL FEATURES			
<b>Supply Voltage</b>	15 - 30 Vdc	<b>Light Receiver</b>	Avalanche photodiode		
<b>Power Consumption</b>	15 W typical 20 W Max. (including startup current)	<b>Wavelength</b>	630 to 680 nm		
<b>Communication Interfaces</b>	<b>Main (isolated)</b>	<b>Baud Rate</b>	<b>Safety Class</b>		
	RS232			1200 to 115200	Class 2-EN 60825-1; Class II-CDRH
	RS485 full-duplex				
	RS485 half-duplex	19200	<b>Laser Control</b>		
	20 mA C.L. (INT-30 with C-BOX 100 only)			Security system to turn laser off in case of motor slow down	
	<b>Auxiliary</b>				
	RS232	1200 to 115200	<b>READING FEATURES</b>		
	<b>Other</b>			Max. Resolution Max. Read. Distance Max. Read. Width Max. Depth of Field  (see reading diagram)	
	Lonworks	1,25 Mb/s			
	Ethernet	10 or 100 Mb/s			
<b>Inputs</b>			<b>USER INTERFACE</b>		
<b>Ext. Trigger 1, 3 aux. digital inputs</b>	(optocoupled NPN or PNP)			<b>LCD Display</b>	
<b>Outputs</b>				2 lines by 16 characters LCD	
<b>3 software programmable digital outputs</b>	(optocoupled)		<b>Keypad</b>	3 keys	
			<b>LED Indicators</b>	Power ON (red color) Phase ON (yellow color) TX Data (green color)	

SOFTWARE FEATURES		ENVIRONMENTAL FEATURES		
<b>Readable Codes</b>	Interleaved 2/5 Code 39 standard Codabar Code 128 EAN 128 Code 93 (Standard & Full ASCII) EAN/UPC (including Add-on 2 And Add-on 5)	<b>Operating Temperature</b>	0° to +40 °C (+32 to +104 °F)	
		<b>Storage Temperature</b>	-20° to +70 °C (-4° to +158 °F)	
<b>Code Selection</b>	Up to 10 codes during one reading phase	<b>Humidity</b>	90% non condensing	
		<b>Ambient Light Immunity</b>	3500 lux	
<b>Headers and Terminators</b>	Up to 128-byte headers and 128-byte terminators	<b>Vibration Resistance</b>	14 mm @ 2 to 10 Hz IEC 68-2-6 test FC 1.5 mm @ 13 to 55 Hz 2 hours on each axis	
		<b>Shock Resistance</b>	30 g; 11 ms	
<b>Operating Modes</b>	On Line, Automatic, Test, PackTrack™	<b>Protection Class</b>	IP64	
<b>Config. Mode</b>	Genius™ utility program	PHYSICAL FEATURES		
<b>Parameter Storage</b>	Non-volatile internal FLASH		<b>Std Models</b>	<b>Oscill. Mirror</b>
		<b>Dimensions mm (inch)</b>	110x113x99 (4.33x4.45x3.9)	113x180x104.5 (4.45x7.08x4.11)
		<b>Weight</b>	1.5 kg (3.3 lb)	2.0 kg (4.4 lb)

## Accessories:

Name	Description	Part Number
CAB-6011	Cable to C-BOX100 1 m	93A051221
CAB-6012	Cable to C-BOX100 2 m	93A051222
CAB-6015	Cable to C-BOX100 5 m	93A051223
C-BOX 100	Passive connection box	93ACC1510
INT-30	20 mA C.L. interface board for C-BOX 100	93A151022
GFC-60	90° mirror	93A201100
GFC-600	90° mirror close distance	93A201102
PWR-120	Power unit 110/230 V AC - 24 V DC	93ACC1530
BTK-6000	Terminator kit (5 pcs)	93ACC1710
PG6002	Single unit power supply – US	93ACC1718
PG6001	Single unit power supply – UK	93ACC1719
PG6000	Single unit power supply – EU	93ACC1720
FBK-6000	Fast bracket kit (2 pcs)	93ACC1721
US-60	Mounting bracket kit (5 pcs) for multisided stations	890001020
MEP-542	Photocell kit – PNP	93ACC1727
MEP-543	Photocell kit – NPN	93ACC1728
OEK-2	Optical encoder (10 m cable + spring)	93ACC1770
OEK-1	Optical encoder kit + 10 m cable	93ACC1600

## Electrical Connections:

The DS6500 DeviceNet reader provides a 26-pin male D-sub connector for connection to power supply and input/output signals.

A DeviceNet connector is used for connection to the remote Host, while a local Lonworks 9-pin female connector connects the DeviceNet master to the first slave reader of the system.



**NOTE** *When using DeviceNet, the Main serial interface is disabled and must not be physically connected.*

The details of the connector pins are indicated in the following table:

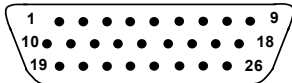
26-pin D-Sub Connector Pinout				
Pin	Name	Function		
1	CHASSIS	Chassis - internally connected to GND		
20	RXAUX	Cable shield connected to chassis		
21	TXAUX	Receive data of auxiliary RS232 (referred to GND)		
8	OUT 1+	Transmit data of auxiliary RS232 (referred to GND)		
22	OUT 1-	Configurable digital output 1 – positive pin		
11	OUT 2+	Configurable digital output 1 – negative pin		
12	OUT 2-	Configurable digital output 2 – positive pin		
16	OUT 3A	Configurable digital output 2 – negative pin		
17	OUT 3B	Configurable digital output 3 – polarity insensitive		
18	EXT_TRIG/PS A	Configurable digital output 3 – polarity insensitive		
19	EXT_TRIG/PS B	External trigger (polarity insensitive) for PS		
6	IN2/ENC A	External trigger (polarity insensitive) for PS		
10	IN2/ENC B	Input signal 2 (polarity insensitive) for Encoder		
14	IN3A	Input signal 2 (polarity insensitive) for Encoder		
15	IN4A	Input signal 3 (polarity insensitive)		
24	IN_REF	Input signal 4 (polarity insensitive)		
9, 13	VS	Common reference of IN3 and IN4 (polarity insensitive)		
23, 25, 26	GND	Supply voltage – positive pin		
		Supply voltage – negative pin		
 <b>26-pin male D-sub Connector</b>				
Pin	RS232	RS485 Full-Duplex	RS485 Half-Duplex	20 mA C.L. (INT-30 with C-BOX 100 only)
2	TX	TX485+	RTX485+	see INT-30 instructions
3	RX	RX485+	RTX485+	
4	RTS	TX485-	RTX485-	
5	CTS	RX485-	RTX485-	
7	GND_ISO	GND_ISO	GND_ISO	

\* For 20 mA C.L. connections, GND is the same of the scanner power supply.

9-pin Lonworks Connector Pinout		
Pin	Name	Function
1	CHASSIS	Cable shield internally connected by capacitor to chassis
9	VS	Supply voltage – positive pin
2	GND	Supply voltage – negative pin
6	VS_I/O	Supply voltage of I/O circuit
3	Ref_I/O	Reference voltage of I/O circuit
4	SYS_ENC_I/O	System signal
5	SYS_I/O	System signal
7	LON A	Lonworks line (polarity insensitive)
8	LON B	Lonworks line (polarity insensitive)

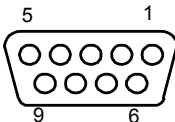
  
**9-pin female Local Lonworks Connector**

5-pin DeviceNet Connector Pinout		
Pin	Name	Function
2	V+	Supply voltage – positive pin
5	CAN_L	CAN bus data line – L
1	SHIELD	Shield
4	CAN_H	CAN bus data line – H
3	V-	Supply voltage – negative pin

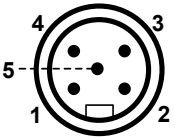
  
**5-pin male DeviceNet Connector**



**NOTE**

The power supplied on pin V+ and V- is used only to propagate power to the section of the DeviceNet board directly connected to the Bus. It is completely isolated from the DS6500 power which must be supplied on pin 9, 13 and pin 23, 25 of the 26-pin Main/Aux connector.

## Connectivity:

### Point-to-Point Layout

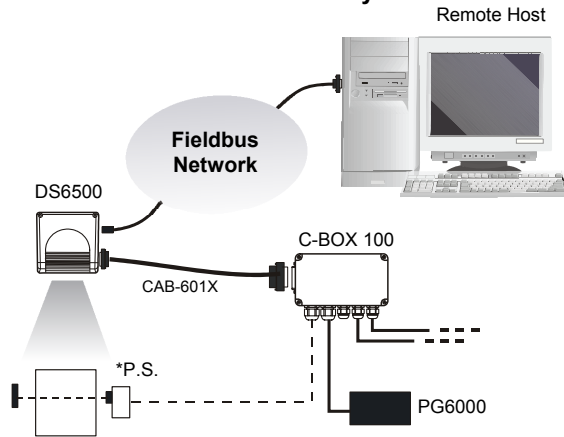

\* P.S. (Presence Sensor) connected to External Trigger/PS input.

### Pass Through Layout

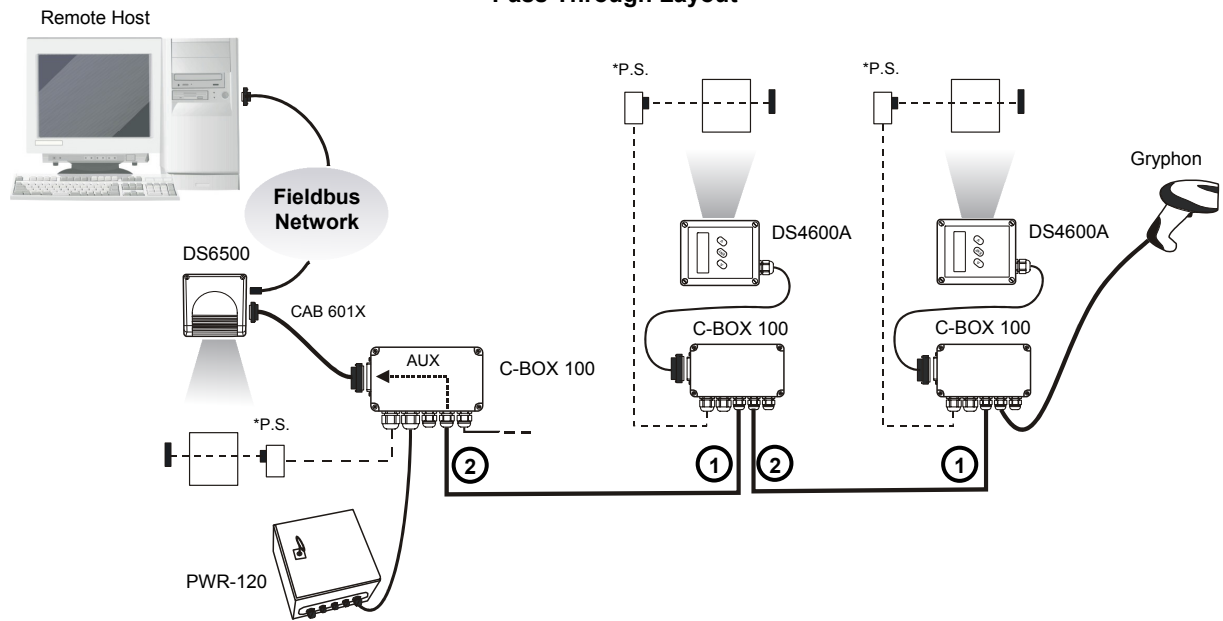

① Main Serial Interface      ② Auxiliary Serial Interface

\* P.S. (Presence Sensor) connected to External Trigger/PS input.

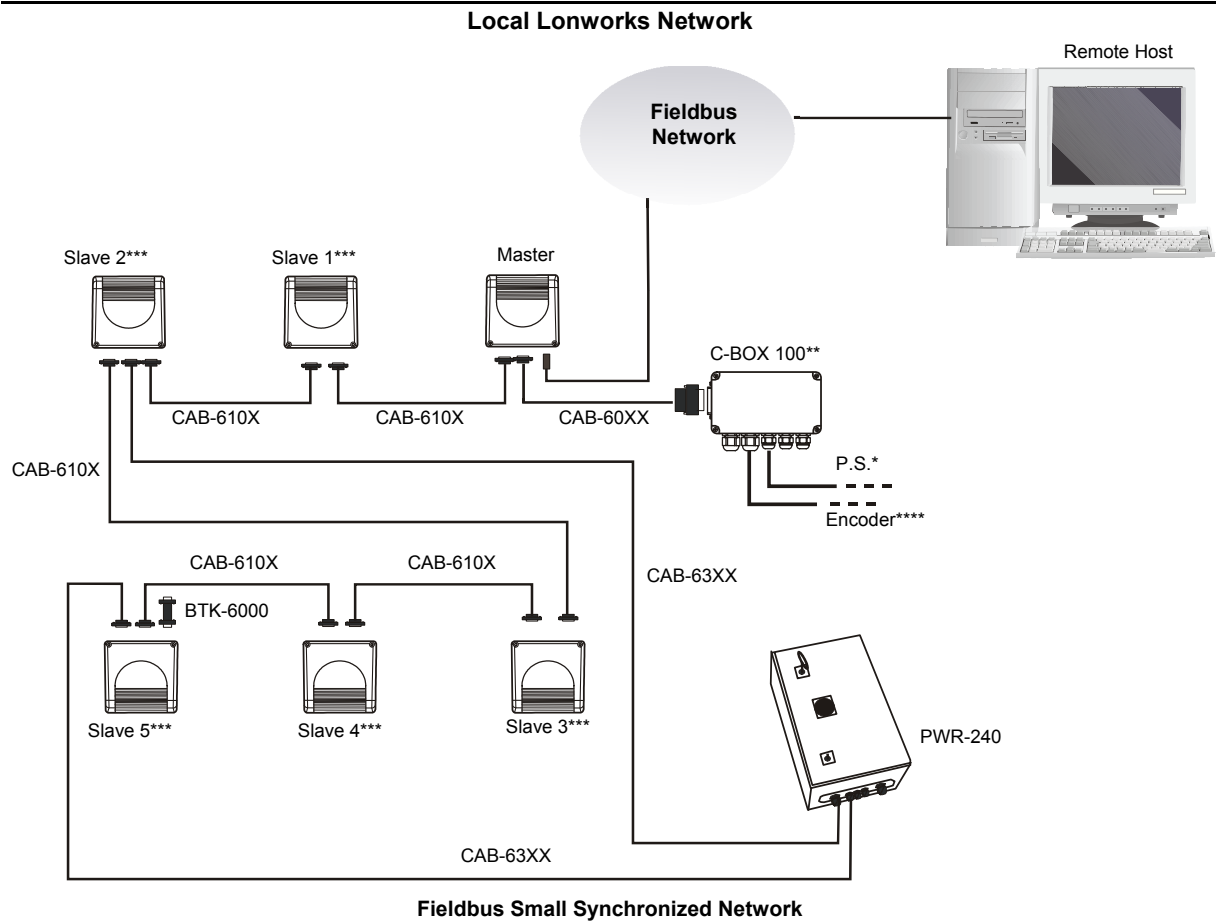

- \* P.S. (Presence Sensor) connected to External Trigger/PS input.
- \*\* C-BOX 100 modified to accept scanner power.
- \*\*\* The Slave scanners are Master/Slave models, which allow Lonworks network propagation.
- \*\*\*\* Encoder connected to IN2/ENC input.



## DS6500-105-0XX OSCILLATING MIRROR MODEL

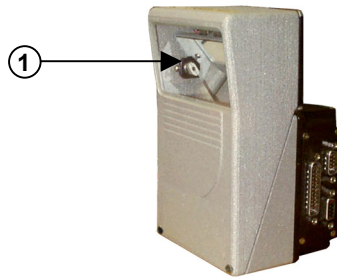

**Figure A**

① Laser Beam Output Window

Oscillating mirror models are used when coverage of a large reading area is required, mainly in picket fence applications.

The DS6500 scanner mounts a dedicated optic head with integrated oscillating mirror driven by a linear motor.

The speed, precision, repeatability, and reliability of this driving technology assure high level performance.

The new oscillating mirror is completely software controlled and software programmable. The Genius™ software tool allows adjusting the linear motor speed (oscillating frequency) and the upper and lower limits of the oscillation by defining the top and bottom line limit angles.

When the oscillating mirror is programmed to read barcode labels at very small angles, position the reader to **assure at least 10°** for the Skew angle (see DS6500 Reference Manual). This angle refers to the most inclined or external laser line, so that all other laser lines assure more than 10° Skew. This avoids the direct reflection of the laser light emitted by the reader.

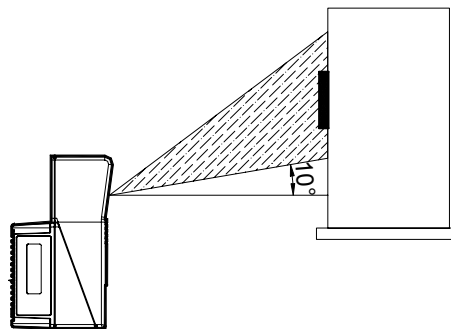

**Oscillating Mirror Skew Angle**

Otherwise, the scanner can be mounted at an angle of inclination of 17.5° in order to attain symmetrical deflection ranges.

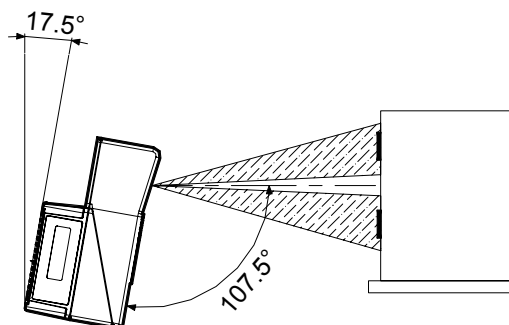

**Oscillating Mirror Reading Position**

In the above case, the zone where the scan line is perpendicular to the reflecting surface corresponds to a neutral zone at the center of the reading field.

The mirror can be deflected up to 40°. Oscillation with respect to the output window median axis is asymmetrical (see figure below).



**Oscillating Mirror Maximum Aperture and Asymmetry**

By configuring the oscillating speed up to the maximum value of 19 Hz, raster emulation can be performed for reading fast moving objects.

Hz	Max. Aperture
0-5	40°
6-10	30°
11-15	20°
16-19	10°



**NOTE**

*By limiting the raster width to the minimum necessary, the number of scans on the reading surface is increased.*

Oscillating angles are selected in software where the minimum and maximum angles correspond to -2.5° and +37.5°.

The scanner can be tilted in order for the 17.5° software setting to correspond with the 0° horizontal plane.

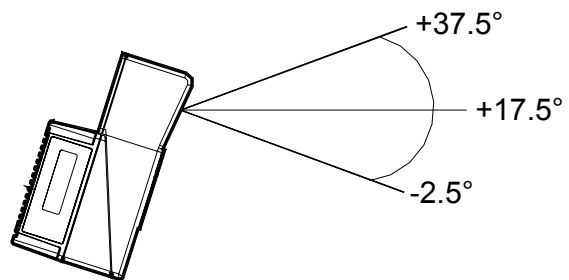

**Oscillating Mirror Extreme Angle Positions**

These models provide higher scanning speed (1200 scans/sec) compared to standard models and the reading performance is not adversely effected by the oscillating mirror.

The example represents the selection of an angle of +10° for the bottom line and an angle of +20° for the top line (see figure beside).

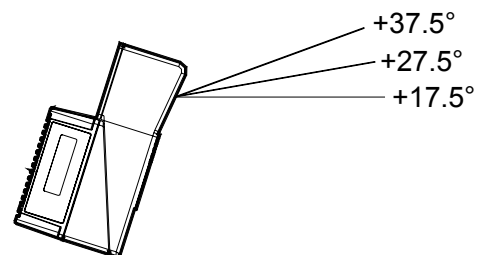

**Oscillating Mode**

## COMMON FEATURES

### C-BOX 100 Pinout for DS6500:

The table below gives the pinout of the C-BOX 100 terminal block connectors. Use this pinout when the DS6500 reader is connected in a network by means of the C-BOX 100:

C-BOX 100 Terminal Block Connectors				
<b>Power</b>				
1, 3, 5	VS			
2, 4, 6	GND			
7, 8	EARTH GROUND			
20, 40	Reserved			
<b>Inputs</b>				
27	EXT TRIG/PS A (polarity insensitive) for PS			
28	EXT TRIG/PS B (polarity insensitive) for PS			
29	IN 2/ENC A (polarity insensitive) for Encoder			
30	IN 2/ENC B (polarity insensitive) for Encoder			
31, 33	IN 3A (polarity insensitive)			
32, 34	IN 4A (polarity insensitive)			
36	IN 3B/IN 4B Reference (polarity insensitive)			
<b>Outputs</b>				
21	OUT 1+			
22	OUT 1-			
23	OUT 2+			
24	OUT 2-			
25	OUT 3A (polarity insensitive)			
26	OUT 3B (polarity insensitive)			
<b>Auxiliary Interface</b>				
35	TX AUX			
37	RX AUX			
38, 39	GND			
<b>Main Interface</b>				
	<b>RS232</b>	<b>RS485 Full-Duplex</b>	<b>RS485 Half-Duplex</b>	<b>20 mA C.L. (with INT-30 only)</b>
11, 15	TX 232	TX 485+	RTX 485+	
12, 16	RTS 232	TX 485-	RTX 485-	
17	RX 232	RX 485+		see INT-30
18	CTS 232	RX 485-		instructions
10, 14, 19	SGND Main Isolated	SGND Main Isolated	SGND Main Isolated	
9, 13		RS485 Cable Shield	RS485 Cable Shield	

### Mechanical Installation:

The DS6500 reader can be positioned and installed in the best way possible as a result of the Step-A-Head™ feature. Thanks to the separation between Head and Base, you can modify the orientation of the decoder base, and therefore display-keypad and connector panels, while keeping the optic head in the correct reading position. The reading head and the decoder base can be rotated independently from each other allowing the installation even in the most critical locations.

To rotate the head follow the given procedure:

1. detach the head from the base by unscrewing the four fixing screws;
2. rotate the head in the desired position;
3. loosen but don't remove the two screws on top of the head;
4. affix the head onto the base carefully aligning the four fixing screws and progressively tightening them about half-way;
5. completely tighten the two screws on top of the head;
6. completely tighten the four fixing screws.

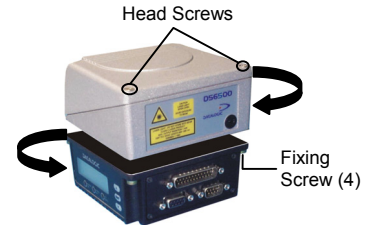

**Step-A-Head™ Feature**

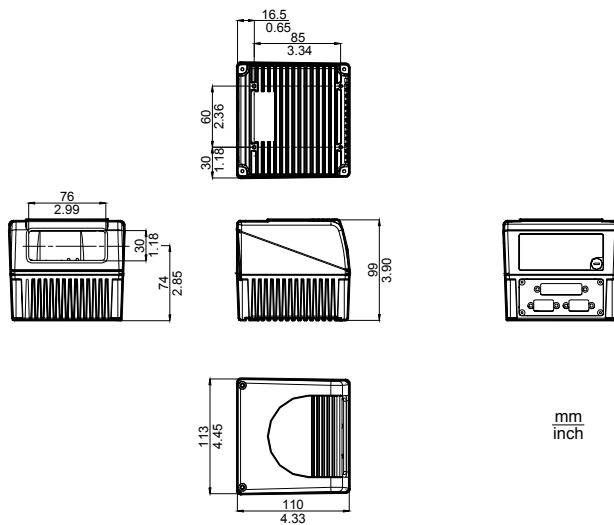

**DS6500 Overall Dimensions**

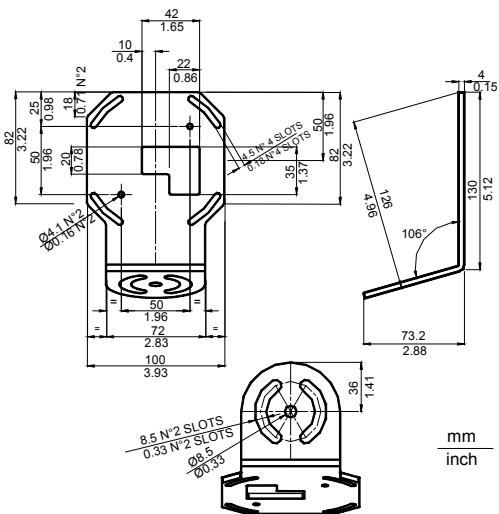

**ST-237 Mounting Bracket Overall Dimensions**

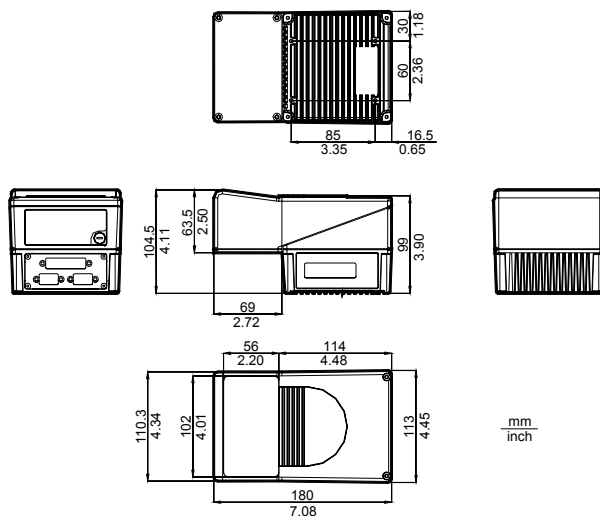

**DS6500 Oscillating Mirror Model Overall Dimensions**

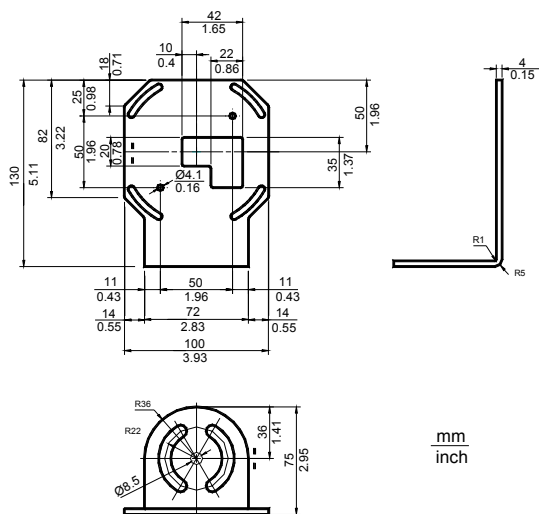

**ST-210 Mounting Bracket Overall Dimensions**

## Typical Installations:

### Standard Installation

The DS6500 scanner is mounted on the ST-237 106° mounting bracket which guarantees a built-in Skew angle (**S** in the figure below) of 16° with respect to the frame plane (typically the Skew angle should be between 10° - 20°). This avoids the direct reflection of the laser light emitted by the scanner. Furthermore, the bracket guides allow adjusting the Tilt angle (**T** in the figure below, which is typically 0°) for the best scanner orientation:

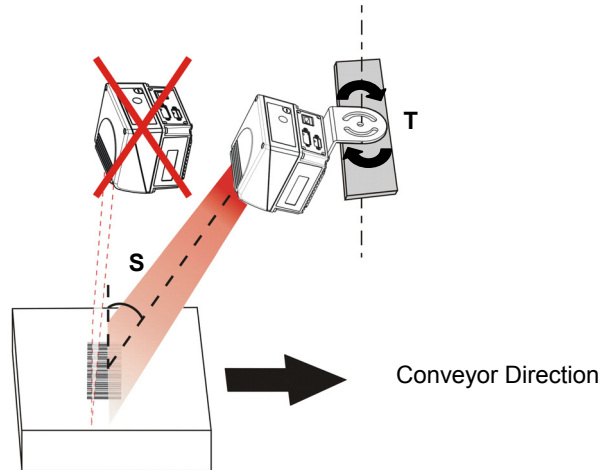

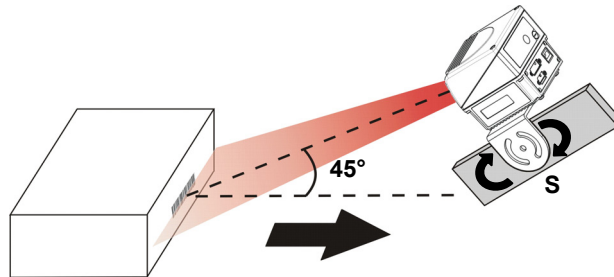

### "45° Skew" Installation

The DS6500 scanner is mounted on the ST-210 90° mounting bracket. By adjusting the mounting bracket guides, reach 45° for the Skew angle (**S** in the figure below) to avoid the direct reflection of the laser light emitted by the scanner:



 <b>ATTENTION</b>	<p>If using the "45° Skew" installation, it is not guaranteed that the scanner reading performances (see reading diagram section) will match those measured for the standard installation with Skew angle between 10° - 20°.</p>
---	--

 <b>NOTE</b>	<p>The ST-210 mounting bracket is an accessory of the DS6500 standard model available in the US-60 kit (order no. 890001020).</p>
--	---

 <b>WARNING</b>	<p>When installing several scanners, take care to position them correctly so that no laser beam enters the reading window perpendicularly and at the same level of the output beam of the other scanners. This condition could occur more frequently for side mounted applications. If these precautions are not followed, it may occur that the laser of the blinded scanner starts blinking due to an internal circuit which temporarily turns the laser off when detecting a power anomaly. To resolve this problem, it is sufficient to slightly change the inclination and position of one of the two scanners involved.</p>
---	---

## Reading Conditions:

- ANSI Grade B minimum
- 800 scans/sec

The following tables describe the requirements for standard applications.

Conveyor Speed (m/s)		Minimum Code Height for ACR Reading (mm)											
		45°						30°					
		0.5	1	1.5	2	2.5	3	0.5	1	1.5	2	2.5	3
2/5 Interleaved Code Resolution (mm)	0.25	10	12	14	16	18	20	7	9	10	12	13	15
	0.30	12	14	15	17	19	21	8	9	11	12	14	15
	0.33	13	14	16	18	20	22	8	10	11	13	14	16
	0.38	14	16	18	19	21	23	9	11	12	14	15	17
	0.50	18	19	21	23	25	26	11	12	14	15	17	18
	0.72	24	25	27	28	30	32	15	16	17	19	20	22
	1.00	33	34	35	36	38	40	20	21	22	23	25	26

Ratio 3:1

Table 1

Conveyor Speed (m/s)		Minimum Code Height for ACR Reading (mm)											
		45°						30°					
		0.5	1	1.5	2	2.5	3	0.5	1	1.5	2	2.5	3
Code 39 Code Resolution (mm)	0.25	9	10	12	14	16	17	6	7	9	10	12	13
	0.30	10	11	13	15	17	18	7	8	9	11	12	14
	0.33	11	12	13	15	17	19	7	8	10	11	13	14
	0.38	12	13	14	16	18	20	8	9	10	12	13	15
	0.50	15	16	17	18	20	22	10	10	11	13	14	16
	0.72	20	21	22	23	24	26	13	13	14	15	17	18
	1.00	27	28	29	30	31	32	17	17	18	19	20	21

Ratio 3:1; Interdigit = Module Size

Table 2

Conveyor Speed (m/s)		Minimum Code Height for ACR Reading (mm)											
		45°						30°					
		0.5	1	1.5	2	2.5	3	0.5	1	1.5	2	2.5	3
Code 128 – Ean 128 Code Resolution (mm)	0.25	8	9	11	13	15	17	5	7	8	10	11	13
	0.30	8	10	12	14	16	18	6	7	9	10	12	13
	0.33	9	11	13	14	16	18	6	8	9	11	12	14
	0.38	10	11	13	15	17	19	7	8	10	11	13	14
	0.50	12	13	15	17	19	21	8	9	11	12	14	15
	0.72	16	17	19	21	22	24	10	11	13	14	16	17
	1.00	22	23	24	25	27	29	13	14	15	17	18	20

Table 3

Conveyor Speed (m/s)		Minimum Code Height for ACR Reading (mm)											
		45°						30°					
		0.5	1	1.5	2	2.5	3	0.5	1	1.5	2	2.5	3
Codabar Code Resolution (mm)	0.25	8	9	11	13	15	17	5	7	8	10	11	13
	0.30	9	10	12	14	16	18	6	7	9	10	12	13
	0.33	9	11	13	14	16	18	6	8	9	11	12	14
	0.38	10	11	13	15	17	19	7	8	10	11	13	14
	0.50	13	14	15	17	19	21	8	9	11	12	14	15
	0.72	17	18	19	21	22	24	11	12	13	14	16	17
	1.00	23	24	25	26	27	29	14	15	16	17	18	20

Ratio 3:1; Interdigit = Module Size

Table 4

Conveyor Speed (m/s)		Minimum Code Height for ACR Reading (mm)											
		45°						30°					
		0.5	1	1.5	2	2.5	3	0.5	1	1.5	2	2.5	3
EAN 8-13, UPC-A Code Resolution (mm)	0.25	7	9	10	12	14	16	5	6	8	9	11	12
	0.30	8	9	11	13	15	17	6	7	8	10	11	13
	0.33	9	10	11	13	15	17	6	7	9	10	12	13
	0.38	10	11	12	14	16	18	7	7	9	10	12	13
	0.50	12	13	14	15	17	19	8	9	10	11	13	14
	0.72	16	17	18	19	20	22	10	11	12	13	14	16
	1.00	22	23	24	24	25	26	13	14	15	16	16	18

Table 5

### Reading Diagrams:

In the following reading diagrams (0,0) is the center of the laser beam output window.

**DS6500-100-0XX**

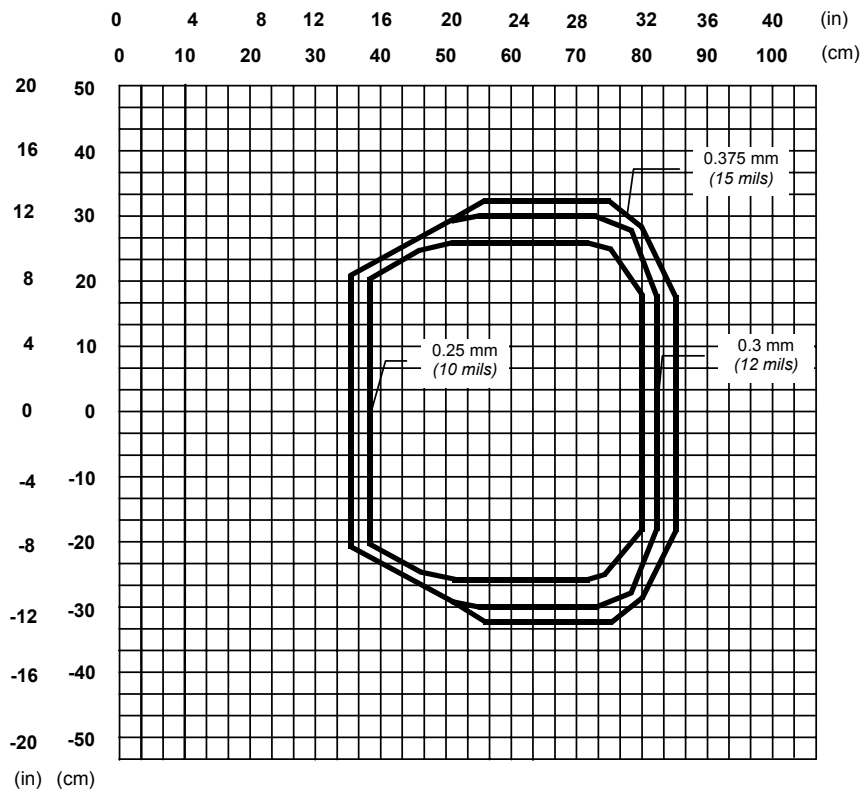

**CONDITIONS**

Code = Interleaved 2/5 or Code 39

PCS = 0.90

Pitch angle = 0°

Skew angle = 10° - 20°

Tilt angle = 0°

**DS6500-105-0XX**

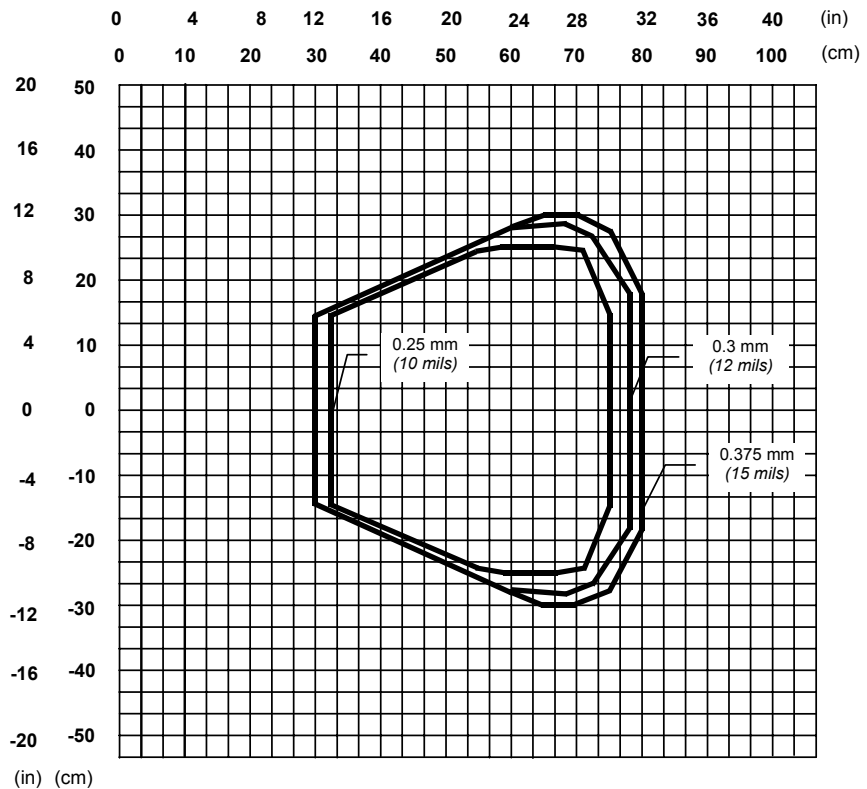

**CONDITIONS**

Code = Interleaved 2/5 or Code 39

PCS = 0.90

Pitch angle = 0°

Skew angle = 10° - 20°

Tilt angle = 0°

## Reading Diagrams:

**DS6500-200-0XX**

0	14	20	26	32	38	44	50	56	62	68	(in)
0	35	50	65	80	95	110	125	140	155	170	(cm)

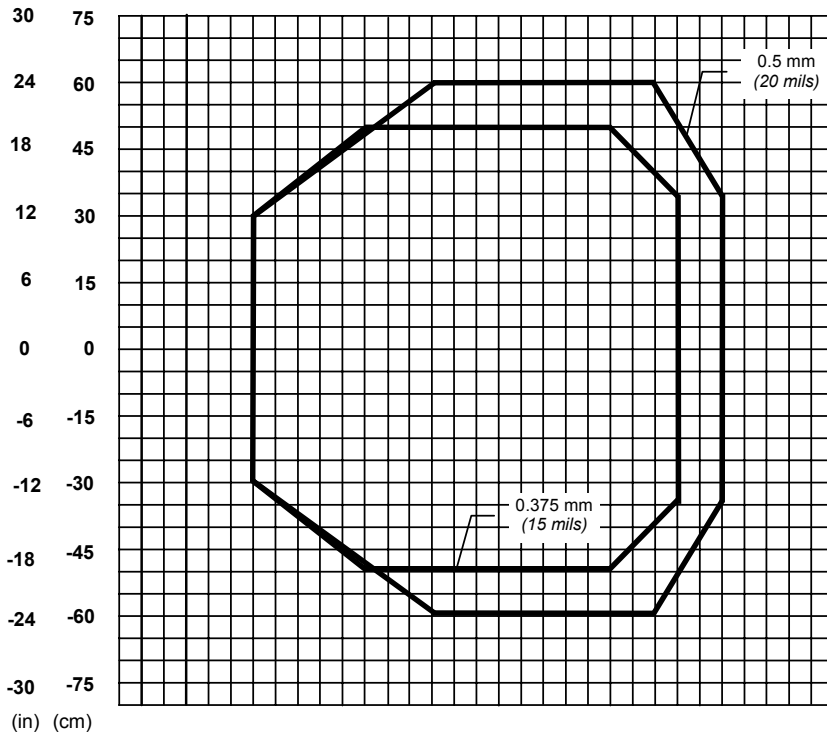

**CONDITIONS**

Code = Interleaved 2/5 or Code 39  
 PCS = 0.90  
 Pitch angle = 0°  
 Skew angle = 10° - 20°  
 Tilt angle = 0°

**DS6500-205-0XX**

0	14	20	26	32	38	44	50	56	62	68	(in)
0	35	50	65	80	95	110	125	140	155	170	(cm)

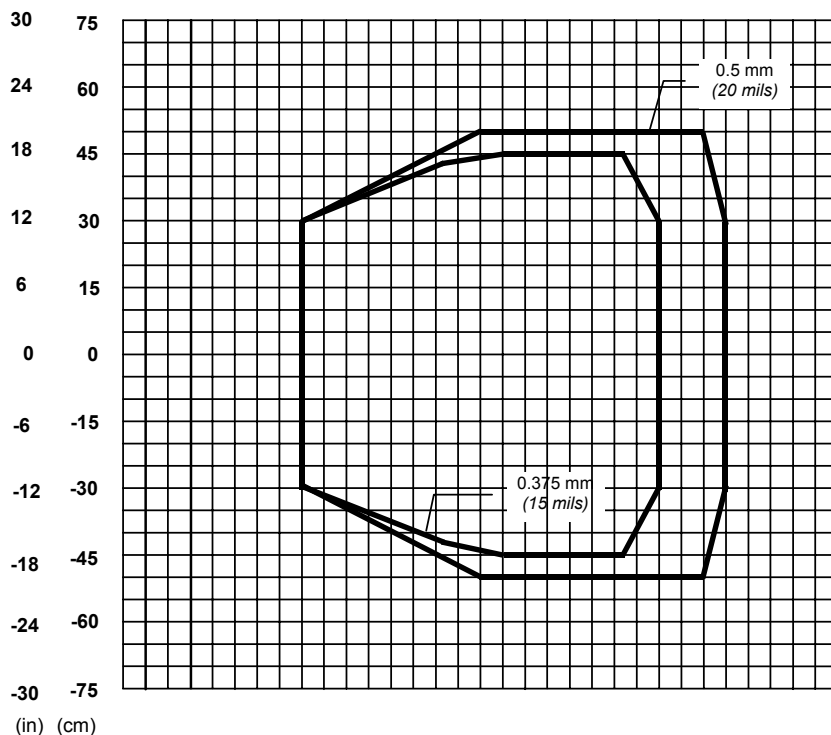

**CONDITIONS**

Code = Interleaved 2/5 or Code 39  
 PCS = 0.90  
 Pitch angle = 0°  
 Skew angle = 10° - 20°  
 Tilt angle = 0°

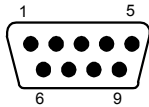
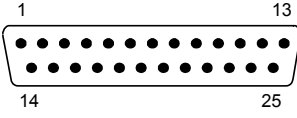

## User Interface:

RS232 PC-side connections			
 <p>9-pin male connector</p>		 <p>25-pin male connector</p>	
Pin	Name	Pin	Name
2	RX	3	RX
3	TX	2	TX
5	GND	7	GND
7	RTS	4	RTS
8	CTS	5	CTS

## How To Build A Simple Interface Test Cable:

The following wiring diagram shows a simple test cable including power, external (push-button) trigger and PC RS232 COM port connections.

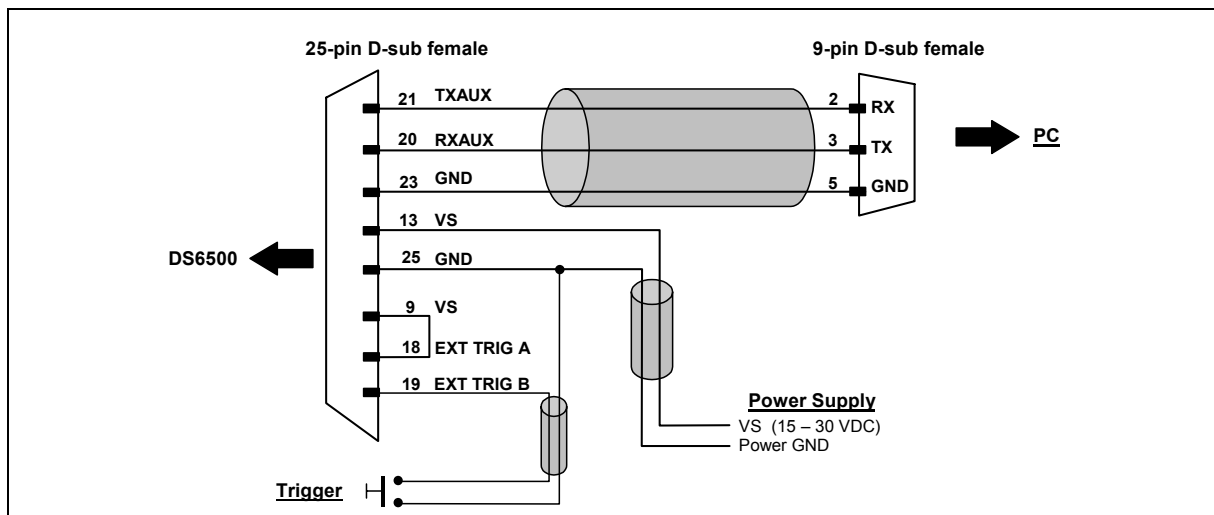

## Compliance:

### Laser Safety

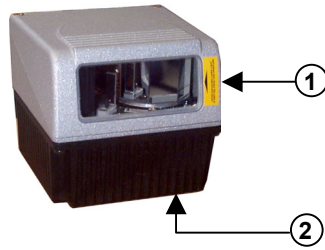

Figure A

- ① Laser Safety Label
- ② Identification Label

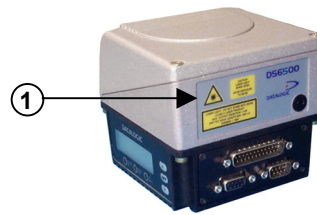

Figure B

- ① Warning and Device Class Label

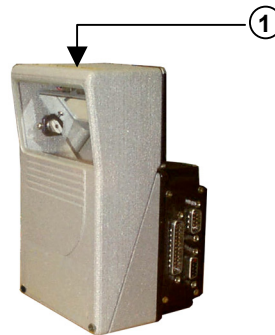

Figure C

- ① Laser Safety Label

The scanner is classified as a Class 2 laser product according to EN 60825-1 regulations and as a Class II laser product according to CDRH regulations.

Disconnect the power supply when opening the device during maintenance or installation to avoid exposure to hazardous laser light.

There is a safety device which allows the laser to be switched on only if the motor is rotating above the threshold for its correct scanning speed.

The laser beam can be switched off through a software command (see also the Genius™ Help On-Line).

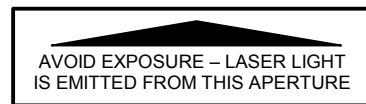

Laser Safety Label for Oscillating Mirror and Standard Models



Warning and Device Class Label

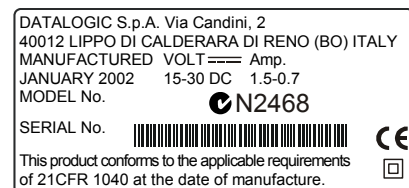

Device Identification Label

The laser diode used in this device is classified as a Class 3B laser product according to EN 60825-1 regulations and as a Class IIIb laser product according to CDRH regulations. As it is not possible to apply a classification label on the laser diode used in this device, the following label is reproduced below:

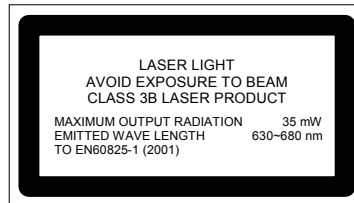

**Laser Diode Class Label**

Any violation of the optic parts in particular can cause radiation up to the maximum level of the laser diode (35 mW at 630 ~ 680 nm).

### Power Supply

- **This product is intended to be installed by Qualified Personnel only.**
- **All DS6500 Models:**  
This device is intended to be supplied by a UL Listed Power Unit marked "Class 2" or LPS power source which supplies power directly to the scanner via the 25/26-pin connector.

### WEEE Compliance



dichiara che  
declares that the  
déclare que le  
bescheinigt, daß das Gerät  
declare que el

**DS6500-XXX-XXX, Laser Scanner**

e tutti i suoi modelli  
and all its models  
et tous ses modèles  
und seine modelle  
y todos sus modelos

sono conformi alle Direttive del Consiglio Europeo sottoelencate:  
are in conformity with the requirements of the European Council Directives listed below:  
sont conformes aux spécifications des Directives de l'Union Européenne ci-dessous:  
der nachstehend angeführten Direktiven des Europäischen Rats:  
cumple con los requisitos de las Directivas del Consejo Europeo, según la lista siguiente:

<b>89/336/EEC EMC Directive</b>	e	<b>92/31/EEC, 93/68/EEC</b>	emendamenti successivi
		and	further amendments
		et	ses successifs amendements
		und	späteren Abänderungen
		y	sucesivas enmiendas

**73/23/EEC Low Voltage Directive**

Basate sulle legislazioni degli Stati membri in relazione alla compatibilità elettromagnetica ed alla sicurezza dei prodotti.  
On the approximation of the laws of Member States relating to electromagnetic compatibility and product safety.  
Basée sur la législation des Etats membres relative à la compatibilité électromagnétique et à la sécurité des produits.  
Über die Annäherung der Gesetze der Mitgliedsstaaten in bezug auf elektromagnetische Verträglichkeit und Produktsicherheit entsprechen.  
Basado en la aproximación de las leyes de los Países Miembros respecto a la compatibilidad electromagnética y las Medidas de seguridad relativas al producto.

---

Questa dichiarazione è basata sulla conformità dei prodotti alle norme seguenti:  
This declaration is based upon compliance of the products to the following standards:  
Cette déclaration repose sur la conformité des produits aux normes suivantes:  
Diese Erklärung basiert darauf, daß das Produkt den folgenden Normen entspricht:  
Esta declaración se basa en el cumplimiento de los productos con la siguientes normas:

<b>EN 55022 (CLASS A ITE), AUGUST 1994:</b> AMENDMENT A1 (CLASS A ITE), OCTOBER 2000:	LIMITS AND METHODS OF MEASUREMENTS OF RADIO DISTURBANCE CHARACTERISTICS OF INFORMATION TECHNOLOGY EQUIPMENT (ITE)
<b>EN 61000-6-2, OCTOBER 2001:</b>	ELECTROMAGNETIC COMPATIBILITY (EMC). PART 6-2: GENERIC STANDARDS - IMMUNITY FOR INDUSTRIAL ENVIRONMENTS
<b>EN 60950-1, DECEMBER 2001:</b>	INFORMATION TECHNOLOGY EQUIPMENT – SAFETY – PART 1: GENERAL REQUIREMENTS
<b>EN 60825-1, JUNE 1994:</b> <b>AMENDMENTS A11 (1996), A2 (2001):</b>	SAFETY OF LASER PRODUCTS – PART 1: EQUIPMENT CLASSIFICATION, REQUIREMENTS AND USER'S GUIDE

Lippo di Calderara, September 8th, 2005

*Ruggero Cacioppo*  
Ruggero Cacioppo  
Quality Assurance Laboratory Manager